

hwam[🔥]
intelligent heat

Since 1973



HWAM 2620c

29-1657 UK

COLLECTION 2021/2022





At HWAM, our talented organization works every day to produce unique and aesthetic products in collaboration with hand-picked quality suppliers to the delight of consumers all over the world. Our wood-burning stoves and stove inserts are manufactured at our factory in Hørning, south of Aarhus, in the heart of Denmark. Here functional design solutions are developed and produced at our modern factory hand in hand with traditional craftsmanship, which ultimately creates the perfect product.

At HWAM, we focus on climate-friendly and CO₂-neutral combustion. We do this through our unique combustion systems which are built into all our products enabling the wood's energy to be utilized in the best and cleanest way possible. All our products are also developed in close collaboration with designers who have a deep understanding of our profession and who not only encapsulate current trends but also embrace the perfect and unique design that classics are made of.

In 2019, HWAM A/S enters a partnership with French SEGUIN Group, as co-owner. HWAM A/S remains under Danish management with Stefan Hvam Pedersen as the CEO. Today, HWAM A/S has a dealer network covering all of Europe. Add to this, importers in a wide range of countries.

Enjoy the new product catalogue. On behalf of us all at Team HWAM.

Stefan Hvam Pedersen
CEO, HWAM A/S



CONTENTS

- 5 Why choose HWAM
- 6 Protect the environment
- 8 HWAM® SmartControl™
- 10 FAQ what to consider before choosing a wood-burning stove
- 13 Heat storage
- 14 Design your own HWAM wood-burning stove
- 16 Meet our designers
- 19 A HWAM wood-burning stove is born

INSPIRATION

- 22 HWAM 2600
- 24 HWAM 3100
- 26 HWAM 3500
- 28 HWAM 3600
- 30 HWAM 3700
- 32 HWAM 4100
- 34 HWAM 4200
- 36 HWAM 4300
- 38 HWAM 4500
- 40 HWAM 4600
- 42 HWAM 5530
- 44 HWAM Classic 4
- 46 HWAM I 40/55
- 48 Accessories

TECHNICAL SPECIFICATIONS

- 54 HWAM 2600
- 56 HWAM 3100
- 58 HWAM 3500
- 59 HWAM 3600
- 62 HWAM 3700
- 64 HWAM 4100
- 67 HWAM 4200
- 68 HWAM 4300
- 69 HWAM 4500
- 72 HWAM 4600
- 74 HWAM 5530
- 76 HWAM Classic 4
- 77 HWAM I 40/55
- 78 Product overview
- 80 Distance to combustible materials
- 82 Test results
- 84 Approvals & registrations

HWAM 3740m, style handle, black



Protect the environment, save money and enjoy a high level of comfort thanks to HWAM® SmartControl™



Efficient combustion and easy operation thanks to HWAM® Autopilot™ which is standard in all HWAM models



Danish and international design



Manufactured in Denmark for more than 45 years



HWAM's unique airwash system ensures correct air circulation and keeps the glass clean



Convenience and ease of operation thanks to HWAM® SmartControl™ or HWAM® Autopilot™



A unique closing mechanism seals the door tightly for optimum combustion



Optional fresh air kit to connect to external air



Convection distributes the heat in the room



Heat storage helps prolong the warmth in your room even after the fire has gone out



WHY CHOOSE HWAM?

Most wood-burning stoves probably look more or less the same to you. So, why choose a HWAM? HWAM has designed and produced wood-burning stoves in Denmark for more than 45 years. It has been an exciting and insightful journey and we have learnt so much from listening to our customers and partners. We test our wood-burning stoves thoroughly and we always give high priority to design, functionality and quality.

Design, functionality and sustainability are key factors in our philosophy. Based on these values, we have developed two intelligent systems for regulating the supply of air thereby optimising the combustion, the mechanical **HWAM® Autopilot™**, as well as the electronic **HWAM® SmartControl™**. You can read more about these two systems from page 6-9 or on our website, www.hwam.com.

When you choose a HWAM wood-burning stove you can design it to your taste and needs. On page 14 you can learn more about the various options and get some inspiration. No matter which model you end up with we promise you to deliver a Danish-produced wood-burning stove of the highest quality. As all of our wood-burning stoves are produced at our factory in Denmark we control the entire process from the very first design drawing till the wood-burning stove is ready to leave the factory.





PROTECT THE ENVIRONMENT

WE DO...

“We constantly strive to make our wood-burning stoves and stove inserts more efficient and environmentally friendly. Therefore, our products are put through a series of comprehensive tests to determine how they perform in different situations. We do this to ensure that the wood-burning stoves and the stove inserts comply with both our own stringent environmental requirements in every conceivable situation. We do this to ensure the best possible experience for the user and to protect the environment.”



Nature needs protecting - now more than ever. You can make a big difference and leave a greener footprint for the enjoyment of future generations by introducing small changes in your life. Start by choosing a HWAM wood-burning stove.

A HWAM wood-burning stove holds a little secret. A secret which has been kept for 30-odd years. It is a heat-sensitive spring at the core of your HWAM wood-burning stove by the name of HWAM® Autopilot™.

Once you have lit the stove, HWAM® Autopilot™ takes over and automatically regulates the air supply. As the heat rises and falls in the combustion chamber, the heat-sensitive spring will cause the three mechanical air dampers to open or close depending on the current temperature in the combustion chamber. In effect, optimum combustion without you having to do anything. Easy, convenient, eco-friendly and economical.

HWAM® Autopilot™ allows you to choose the temperature level that suits you. Simply set the regulation to your requirements. A HWAM wood-burning stove means:

- better comfort
- 40% savings on firewood consumption*
- reduced particle emission*

HWAM® Autopilot™ is standard in all HWAM wood-burning stoves and is included in the price.



WOULD YOU LIKE AN **INTELLIGENT** WOOD-BURNING STOVE?

HWAM® SmartControl™ adjusts the essential air supply in your wood-burning stove. All you have to do is light the fire and add new firewood. HWAM® SmartControl™ will do the rest. You will get a message when it is time to add more firewood.

Once the wood-burning stove has been lit, HWAM® SmartControl™ adjusts the air supply through three independent air inlets. The temperature and the amount of oxygen in the flue gas are constantly measured by a temperature meter and an oxygen meter, respectively, and sent on to the control system. Based on this data, HWAM® SmartControl™ regulates the air inlets with precision to the second, ensuring that the right amount of air is supplied to the combustion chamber, at the right place and at the right time. A win-win for your firewood consumption and the environment!

HWAM® SmartControl™ comes with a thermostat, which allows you to choose the temperature level that suits you. The temperature level is set via an app on your phone.

When you choose a HWAM wood-burning stove* with HWAM® SmartControl™ you get:

- A future-proof wood-burning stove whose system soft-ware is continuously updated
- 50% saving on your firewood consumption**
- Greater comfort thanks to smart control
- A highly eco-friendly wood-burning stove ensuring optimal, clean combustion
- A wood-burning stove recommended for low-energy houses/pressure-tested houses and new houses in general

With HWAM® SmartControl™ you get a wood-burning stove that is not only economical and eco-friendly; it also gives you much more time to enjoy.



PROTECT THE ENVIRONMENT



SAVE MONEY



HIGH LEVEL OF COMFORT



*HWAM® SmartControl™ is available as a separate, additional purchase.
** Compared to a HWAM wood-burning stove without HWAM® SmartControl™.



1



Light the fire as usual

2



Set the desired room temperature on your smartphone

3



Receive a notification when it is time to restoke

WHAT TO CONSIDER BEFORE CHOOSING A WOOD-BURNING STOVE

Taste and style vary from person to person, so here we will let you be the expert. However, before you buy a wood-burning stove, there are a few things worth considering.

Why do you want a wood-burning stove?

Is it because you live in a cold house? Do you want to save money on the heating bill, or is it for the sake of the cosy atmosphere?

How many m² are to be heated?

It is important that the heat emitted by the wood-burning stove is adequate for the m² to be warmed up. As a rule of thumb, you can assume that approximately 1 kW is required to heat 20 m², provided the house is reasonably well insulated. Ask your HWAM dealer for more information.

How easy should it be?

All HWAM stoves are equipped with HWAM® Autopilot™ as standard, an automatic air control that ensures good combustion. If you would like it as easy as it comes, then choose a model with built-in HWAM® SmartControl™. The only thing you need to do is light the fire as usual, set the desired temperature via an app on your smartphone and then enjoy the heat and the dancing flames. You will receive a message through your app when it is time to add new firewood.

Requirements for the location?

Are there any special constructions in your home that render installation of the wood-burning stove impossible in certain areas? Is there anything you should be aware of in relation to combustible material?

Requirements for new houses?

If you live in a newly built house, you may need to install a fresh air system in your wood-burning stove, as newly built houses are very well insulated, and the air circulating in the house is often reused in the ventilation system. This means that there will not be enough air in the house for neither lighting up nor combustion.

Requirements for chimney & smoke pipe

The chimney must be of a sufficient height to enable an adequate draft and to prevent smoke problems. The wood-burning stove requires a draft of at least 12 Pa. The chimney must have a minimum opening equivalent to Ø 15 cm. The chimney opening should always be at least the size of the outlet socket of the stove. The chimney must have an easily accessible soot door. Smoke pipe and chimney must always be suitable for a stove connection. Ask your HWAM dealer for more information.

Requirements for floors and/or walls

You should check whether the floor on which your wood-burning stove will be standing is stable enough to carry the weight, or whether the wall which your stove or insert will hang on/be built into is able to withstand weight. We recommend that you consult a specialist. If the wood-burning stove is placed on a flammable floor, make sure to protect the floor from embers falling out. You can choose tiles, sheet metal or a glass plate depending on what style you prefer. See more about distances to combustible material on page 78.

Ask an expert

Once you have considered some of these questions, it will hopefully be easier for you to make a decision. If you are still in doubt, you can always visit your local HWAM retailer for a talk about the right choice for you.



**YOUR
WOOD-BURNING STOVE
IS CO₂-NEUTRAL**



HWAM 4660C

HEAT STORAGE & STONE CLADDING

When you choose a wood-burning stove with stone cladding, you get a stove with a unique appearance, since every stone has its own distinctive feature. Besides, there are other tangible benefits.

We know of heat storage from masonry stoves, where the heat is stored in the stones surrounding the combustion chamber. Heat storage in a wood-burning stove is the stove's ability to quickly and comfortably distribute the convection heat in the room combined with the masonry stove's capacity for heat storage.

Selected HWAM models are designed with a heat storage compartment that can be filled with stones with a special capacity for storing the heat from the wood-burning stove and then slowly give it off to the room. This means that you can enjoy the heat long after the fire has gone out.

If you want a wood-burning stove that stores the heat, you can choose one of the following HWAM models with stone cladding: 3520, 3640, 3660, 4240, 4340, 4540, 4560, 4640 and 4660.

If you would like a stove with a heat storage compartment, you can choose between these HWAM models: 3130, 3520, 3650, 3660, 3740, 4150, 4160, 4550, 4560, 4660 and 5530.

Below is an illustration of a wood-burning stove with and without heat-storing stones.

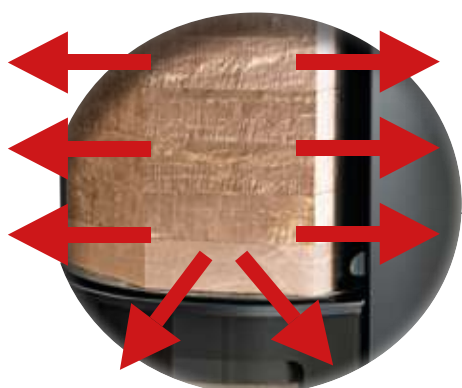

Heat-storing stones

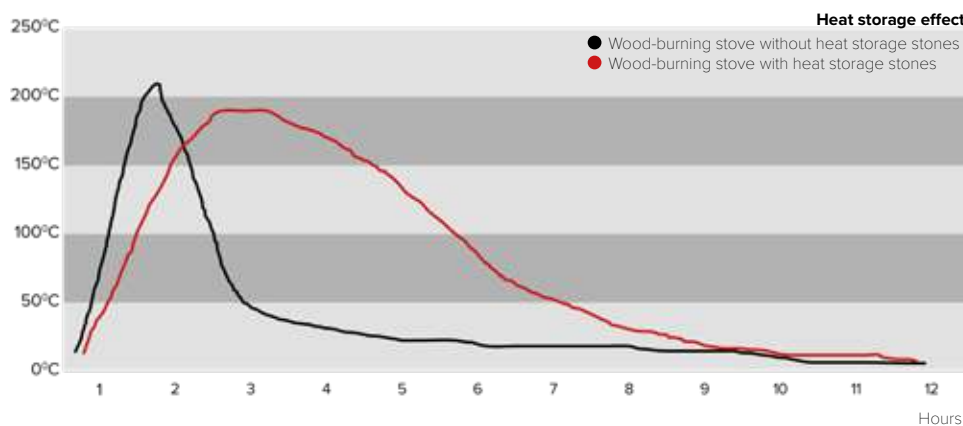

A wood-burning stove with heat storing stone cladding means more continuous heat in the room with the same amount of firewood.



HWAM 4660m

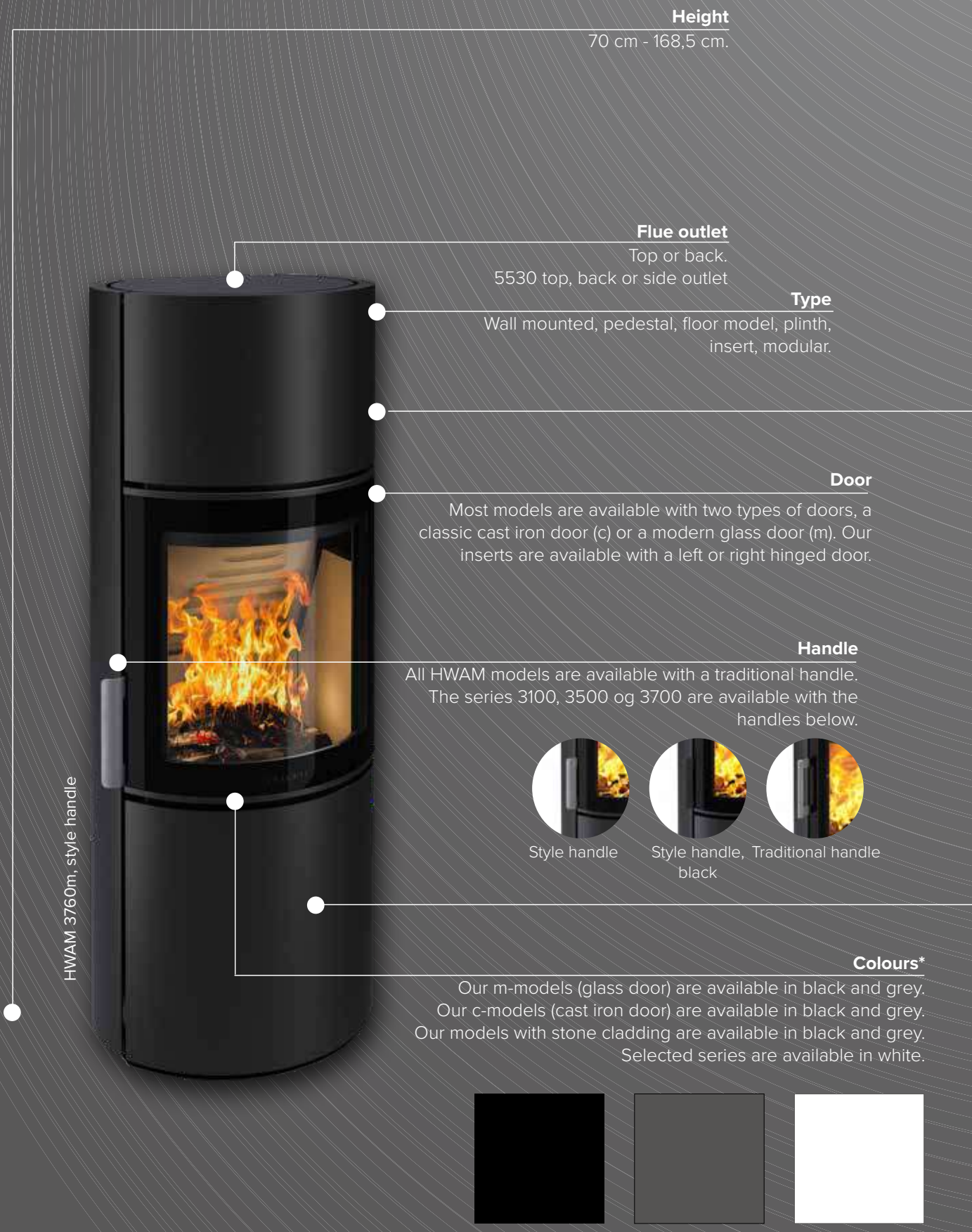

HWAM 3760m, style handle

Height

70 cm - 168,5 cm.

Flue outlet

Top or back.
5530 top, back or side outlet

Type

Wall mounted, pedestal, floor model, plinth, insert, modular.

Door

Most models are available with two types of doors, a classic cast iron door (c) or a modern glass door (m). Our inserts are available with a left or right hinged door.

Handle

All HWAM models are available with a traditional handle. The series 3100, 3500 og 3700 are available with the handles below.



Style handle



Style handle, Traditional handle black

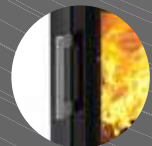

Colours*

Our m-models (glass door) are available in black and grey. Our c-models (cast iron door) are available in black and grey. Our models with stone cladding are available in black and grey. Selected series are available in white.

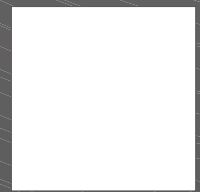

* With the exception of HWAM 5530 and HWAM 140/55.

DESIGN YOUR OWN HWAM WOOD-BURNING STOVE

Once you have decided which model best suits your needs, it is time to choose the perfect look. There are many ways to tailor your stove to exactly fit your style and home. What do you prefer? A classic look? A raw look? Or a modern look?

Under our technical specifications from page 53, you can see all our models. Take a look at the possibilities and find inspiration on how to put together your very own HWAM model.

Natural stone cladding

A wood-burning stove with natural stone cladding has two functions. Visually, the stone creates a unique appearance, with no piece of stone being the same. Purely functionally, the heat-storing capacity of the stone extends the heat effect.

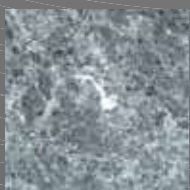

Soapstone

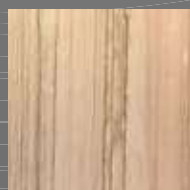

Tobacco



San Sebastian



Rosewood



Nox Petra

Function

All HWAM wood-burning stoves are equipped with HWAM® Autopilot™ as standard to help you achieve good combustion. As the temperature rises and falls in the combustion chamber, a bimetallic spring will expand and contract, thereby regulating the supply of air. When the fire is dying out, the damper will automatically open again, and you can add firewood or let the fire die out.

Would you like it as easy as it comes? Then you should choose a model with built-in HWAM® SmartControl™. HWAM® SmartControl™ is electronic control of the air for optimum combustion. The only thing you need to do is light the fire as usual, set the temperature via an app on your smartphone and enjoy the heat and the dancing flames. You will receive a message through the app when it is time to add more firewood.

MEET OUR DESIGNERS

When design meets function something unique is created. It is difficult to describe in words. It must be seen, touched and experienced. HWAM has a long tradition of working together with talented Danish and international designers. The combination of their sense of aesthetics and detail and the know-how of our experts results in functional handcraft.

The starting point for the development of any HWAM wood-burning stove is optimal combustion and an aesthetically pleasing appearance

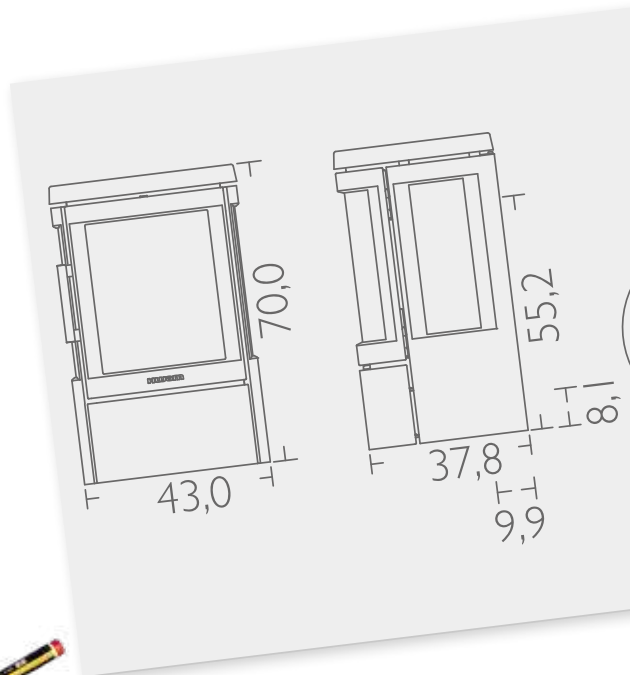

Sørig & Jacobsen



The designer team Sørig & Jacobsen consists of Henrik Sørig and Tobias Jacobsen.

Their design tells a story and plays on the harmony between function, form, and technique. They have a keen eye for details and work with simplicity of appearance and design. Good design is when the stove matches the user's needs perfectly.

Heiko Heybey



German furniture architect Heiko Heybey has dedicated himself to creating modern and everyday-friendly designs.

In his quest to link commercial design with quality craftsmanship, Heiko Heybey has designed countless beautiful wood-burning stoves.

Anders C. FASTERHOLDT



Anders C. FASTERHOLDT always focuses on the function of the wood-burning stove, the needs of the stove-owner and the aesthetic sensuality. He creates stoves and solutions that work in everyday life.

As a designer, he strives to remove all unnecessary noise so that the design is as clean as possible.





HWAM 4660C



 **MADE IN DENMARK**

DANISH DESIGN

MANUFACTURED IN DENMARK

DANISH QUALITY

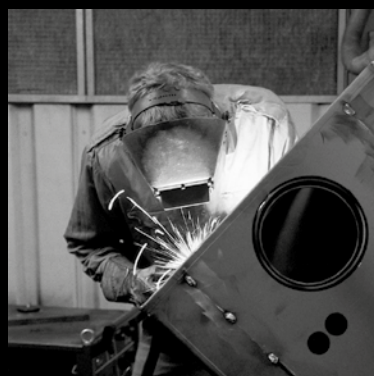

A HWAM WOOD-BURNING STOVE IS BORN

From idea to final product

From idea to wood-burning stove

We believe that innovation and development go hand in hand with production. Take production out of the equation, and you lose the practical knowledge that makes it possible to translate design ideas into real stoves that meet aesthetic as well as functional needs and demands. This is why all our wood-burning stoves and inserts are manufactured at our factory in Hørning and have been for more than 45 years. The process starts with our talented designers whom we have worked with for years. When their ideas and visions have manifested themselves in sketches, they open a dialogue with our designers and sales management for the development of a wood-burning stove or an insert that satisfies the demands of our customers.

Prototypes & tests

When the design drawings are in place, the process moves into our development workshop at the factory in Hørning, where prototypes of the new stove will be prepared. The stove is then tested by our combustion experts to ensure that it meets the stringent requirements for a wood-burning stove. When the wood-burning stove or the insert burns as it should, it is sent for external testing in Denmark and abroad for final approval at a certified test institute.

First production

Once the stove has been approved in relation to combustion and safety requirements, it will be put into production. Each single HWAM wood-burning stove is produced to order at our modern factory, and the processes are implemented and supervised by our highly skilled employees. This ensures a stable flow, better control of production and thus a final stove of outstanding quality.

The devil is in the detail

Our goal is to develop wood-burning stoves and inserts with a unique design which appeal to the quality conscious consumer. And this is where the small details make the difference. One of the features that makes a HWAM stove so unique is a bimetallic spring, HWAM® Autopilot™, which all our stoves are equipped with. It automatically controls the all-important combustion air inside the wood-burning stove, unlike other wood-burning stoves, where you must adjust the air in order to obtain good combustion. Our electronic combustion system, HWAM® SmartControl™, which is available for most HWAM models, takes the technology a step further. Read more on page 8.

We have made it easy for you. This way, you can concentrate on enjoying the warmth and the beautiful enchanting fire.



A bimetallic spring, which automatically controls the combustion air inside the wood-burning stove, is standard in all HWAM wood-burning stoves and inserts.



INSPIRATION

Discover our range, which offers something for everyone. For detailed information on the entire range, see the technical specifications from page 53.

22	HWAM 2600
24	HWAM 3100
26	HWAM 3500
28	HWAM 3600
30	HWAM 3700
32	HWAM 4100
34	HWAM 4200
36	HWAM 4300
38	HWAM 4500
40	HWAM 4600
42	HWAM 5530
44	HWAM Classic 4
46	HWAM I 40/55
48	Accessories



HWAM 2620c

The HWAM 2600-series

For more information on the HWAM 2600-series, see page 52.



HWAM 2610c with side glass and on a plinth



HWAM 2610m with side glass



HWAM 2620c on a pedestal



HWAM 2630c with side glass



HWAM 2640c



HWAM 2640m



SMALL, EFFICIENT & SOPHISTICATED

HWAM 2600 Design by Sørig & Jacobsen

With its practical size, the HWAM 2600-series fits into small and large homes alike and creates a cosy gathering point for you and the ones you hold dear. The HWAM 2600-series is characterised by its beautiful rounded front, which, in combination with very simple lines, lends the stove a timeless expression. A great little wood-burning stove that fits into most homes. Let the flames seduce you and create a pleasant atmosphere in your home. For more information about the HWAM 2600-series, see page 52.



HWAM 2610m

Technical data

Capacity	2-6 kW
Nominal heat output	4.5 kW
Smoke outlet	Ø 150 mm
Energy efficiency class	A
Net efficiency	80.3%
Right hinged door	Classic or modern
Chimney draught, min. (recommended)	12 Pa
Width of combustion chamber	27 cm

Approvals & registrations

- EN 13240
- NS 3058/3059
- BImSchV Stufe 2
- LRV
- RLU*
- Brændeovnsbekendtgørelsen 2018



* Not HWAM 2610 and HWAM 2620

Combustion air system





HWAM 3110c

The HWAM 3100-series

For more information
on the HWAM 3100-series,
see page 54.



Style handle



Style handle,
black



Traditional handle



HWAM 3110c
on a plinth



HWAM 3110c
style handle



HWAM 3110m
on pedestal



HWAM 3120c



HWAM 3120m



HWAM 3130m



NEW
Choose between
3 different types
of handles

POWERFUL & EYE-CATCHING

HWAM 3100 Design by Anders C. Fasterholdt

A timeless wood-burning stove that helps create a nice cosy corner in your home. The HWAM 3100-series is characterised by its beautiful elliptical shape that makes it the centrepiece of the room. The perfectly curved glass window offers an impressive view of the flames and acts as a powerful eye-catcher. It does not always have to be four-square. For more information about the HWAM 3100-series, see page 54.



HWAM 3100c style handle

Technical data

Capacity
Nominal heat output
Smoke outlet
Energy efficiency class HWAM® Autopilot™/ HWAM® SmartControl™
Net efficiency HWAM® Autopilot™/ HWAM® SmartControl™
Right hinged door
Chimney draught, min. (recommended)
Width of combustion chamber

2-7 kW
4.5 kW
Ø 150 mm
A / A+
78.1/83.4%
Classic or modern
12 Pa
33 cm

Approvals & registrations

- EN 13240
- NS 3058/3059
- Art. 15a***
- BlmSchV Stufe 2
- LRV
- RLU**
- Brændeovnsbekendtgørelsen 2018



* Not HWAM® Autopilot™ ** Not HWAM 3110
*** Only HWAM HWAM 3110 and 3120 HWAM® Autopilot™

Combustion air system





HWAM 3520c

NEW
 Choose between
 3 different types
 of handles

The HWAM 3500-series

For more information
 on the HWAM 3500-series,
 see page 56.



Style handle



Style handle,
 black

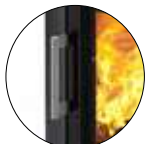

Traditional handle



HWAM 3520c
 style handle



HWAM 3520m



HWAM 3520c
 with soapstone



Choose between
5 different types of
stone cladding

For more information
see page 56

ELEGANT BEAUTY WITH CLEAN LINES

HWAM 3500 Design by Anders C. Fasterholdt

The HWAM 3500-series is an invitation to peace and quiet and a break from the hustle and bustle of everyday life. A wood-burning stove with character whose sculptural idiom contributes to a classic expression in your home. The round forms give the stove character and allow it to be part of the decor, even when not in use. For more information about the HWAM 3500-series, see page 56.



HWAM 3520c, style handle

Technical data

Capacity
Nominal heat output
Smoke outlet
Energy efficiency class HWAM® Autopilot™/ HWAM® SmartControl™
Net efficiency HWAM® Autopilot™/ HWAM® SmartControl™
Right hinged door
Chimney draught, min. (recommended)
Width of combustion chamber

2-7 kW
4.5 kW
Ø 150 mm
A / A+
78.1/83.4%
Classic or modern
12 Pa
33 cm

Approvals & registrations

- EN 13240
 - NS 3058/3059
 - Art. 15a*
 - BlmSchV Stufe 2
 - LRV
 - RLU
 - Brændeovnsbekendtgørelsen 2018
- * Not HWAM® Autopilot™ **Not HWAM® SmartControl™



Combustion air system





HWAM 3630c

The HWAM 3600-series

For more information on the HWAM 3600-series, see page 57.



HWAM 3630c with side glass



HWAM 3640c with soapstone



HWAM 3640m



HWAM 3650c with side glass



HWAM 3650m with side glass



HWAM 3660c



HWAM 3660m



HWAM 3660m with soapstone



Choose between
5 different types of
stone cladding

For more information
see page 57

PERFECT PROPORTIONS

HWAM 3600 Design by Sørig & Jacobsen

Create the most beautiful frames in your home with room for good company and good times in front of the stove. Magical moments when you forget about time and place and just live for the moment. The modern technology is hidden behind HWAM 3600-series minimalistic exterior to allow you to enjoy the fire, the cosiness and the heat in style. For more information about the HWAM 3600-series, see page 57.



Technical data

Capacity	3-9 kW
Nominal heat output	6.0 kW
Smoke outlet	Ø 150 mm
Energy efficiency class HWAM® Autopilot™/ HWAM® SmartControl™	A / A+
Net efficiency HWAM® Autopilot™/ HWAM® SmartControl™	78.3/80.7%
Right hinged door	Classic or modern
Chimney draught, min. (recommended) HWAM® Autopilot™/ HWAM® SmartControl™	11/12 Pa
Width of combustion chamber	35 cm

Approvals & registrations

- EN 13240
 - NS 3058/3059
 - Art. 15a*
 - BlmSchV Stufe 2
 - LRV
 - RLU
 - Brændeovnsbekendtgørelsen 2018
- * Not HWAM® Autopilot™ ** Not HWAM® SmartControl™ *** Not HWAM 3660



Combustion air system



STYLISH DESIGN

HWAM 3700 Design by Sørig & Jacobsen

With the HWAM 3700 series, the designers have created a slender wood-burning stove, whose design language is reminiscent of straight columns. The range is available with the classic HWAM handle or with a new type of handle integrated into the design to offer a calm and unbroken look. At the top of the wood-burning stove, the designers have created a convection groove which emphasises the sleek shape of the stove and completes the stylish look. If the flue pipe is to be connected from the rear of the wood-burning stove, the stove comes with a solid top plate that supports the stylish look. For more information on the HWAM 3700-series, see page 60.



HWAM 3740m with style handle



Choose between
3 different types of
handles

The HWAM 3700-series

For more information
on the HWAM 3700-series,
see page 60.





HWAM 3740c

Technical data

Capacity	2-7 kW
Nominal heat output	4.5 kW
Smoke outlet	Ø 150 mm
Energy efficiency class HWAM® Autopilot™/ HWAM® SmartControl™	A / A+
Net efficiency HWAM® Autopilot™/ HWAM® SmartControl™	78.1/83.4%
Right hinged door	Classic or modern
Chimney draught, min. (recommended)	12 Pa
Width of combustion chamber	33 cm

Approvals & registrations

- EN 13240
 - NS 3058/3059
 - Art. 15a*
 - BImSchV Stufe 2
 - LRV**
 - Brændeovnsbekendtgørelsen 2018
- * Only HWAM® SmartControl™



Combustion air system



SLENDER & CYLINDRICAL

HWAM 4100 Design by Heiko Heybey

The HWAM 4100-series was inspired by the most complete of all forms: the circle. By choice, the design is as pure as possible, as evidenced by the simple joints and the slim handle. A solid top plate gives the stove its finishing touch. The cylindrical shape of the wood-burning stove fits well into a corner or up against a straight wall. For more information on the HWAM 4100-series, see page 62.



HWAM 4130



The HWAM 4100-series

For more information on the HWAM 4100-series, see page 62.



Top outlet



Rear outlet



HWAM 4110 with side glass



HWAM 4120



HWAM 4130 with side glass



HWAM 4140



HWAM 4150 with side glass



HWAM 4160



HWAM 4140

Technical data

Capacity	2-7 kW
Nominal heat output HWAM® Autopilot™/ HWAM® SmartControl™	4.7/4.9 kW
Smoke outlet	Ø 150 mm
Energy efficiency class HWAM® Autopilot™/ HWAM® SmartControl™	A⁺ / A⁺
Net efficiency HWAM® Autopilot™/ HWAM® SmartControl™	82/86%
Left hinged door	Left hinged
Chimney draught, min. (recommended)	12 Pa
Width of combustion chamber	28.4-35.8 cm

Approvals & registrations

- EN 13240
- NS 3058/3059
- Art. 15a
- BImSchV Stufe 2
- LRV
- Brændeovnsbekendtgørelsen 2018



Combustion air system



SOFT CURVED LINES

HWAM 4200 Design by Heiko Heybey

The HWAM 4200-series is characterized by soft curved lines and a distinctive steel frame door. The design is completed with hidden hinges and a large window offering you a great view of the dancing flames. For more information on the HWAM 4200-serien, see page 65.



HWAM 4240, San Sebastian



Choose between
5 different types of
stone cladding

For more information
see page 65

The HWAM 4200-Series

For more information
on the HWAM 4200-series,
see page 65.



HWAM 4240



HWAM 4240
with soapstone



HWAM 4240
with Nox Petra



HWAM 4240
with Tobacco



HWAM 4240

Technical data

Capacity
 Nominal heat output HWAM® Autopilot™/ HWAM® SmartControl™
 Smoke outlet
 Energy efficiency class HWAM® Autopilot™/ HWAM® SmartControl™
 Net efficiency HWAM® Autopilot™/ HWAM® SmartControl™
 Left hinged door
 Chimney draught, min. (recommended)
 Width of combustion chamber

2-7 kW
 4.7/4.9 kW
 Ø 150 mm

 82/86%

12 Pa
 28.4-35.8 cm

Approvals & registrations

- EN 13240
- NS 3058/3059
- Art. 15a
- BImSchV Stufe 2
- LRV
- Brændeovnsbekendtgørelsen 2018



Combustion air system





HWAM 4340 soapstone

The HWAM 4300-series

For more information on the HWAM 4300-series, see page 66.



HWAM 4340



HWAM 4340 with soapstone



HWAM 4340 with Rosewood



HWAM 4340 with Tobacco



Choose between
5 different types of
stone cladding

For more information
see page 66

A MODERN INTERPRETATION OF CLASSIC DESIGN

HWAM 4300 Design by Heiko Heybey

The HWAM 4300-series is a modern interpretation of the classic wood-burning stoves of the 70s with a clear division between wood magazine, combustion chamber and top plate but a more experimental approach to the side elements. The 4300-series presents itself beautifully with its slender oval profile, a wide combustion chamber that can take firewood of up to 33 cm in length, which ensures efficient heating of large rooms. The frame less glass door gives the series a light and modern look and makes it fit for most homes. For more information on the HWAM 4300-serien, see page 66.



Technical data

Capacity
Nominal heat output
Smoke outlet
Energy efficiency class HWAM® Autopilot™/ HWAM® SmartControl™
Net efficiency HWAM® Autopilot™/ HWAM® SmartControl™
Left hinged door
Chimney draught, min. (recommended)
Width of combustion chamber

3-8 kW
6.0 kW
Ø 150 mm
 /

12 Pa
38.2 cm

Approvals & registrations

- EN 13240
- NS 3058/3059
- Art. 15a
- BlmSchV Stufe 2
- LRV
- Brændeovnsbekendtgørelsen 2018



Combustion air system





HWAM 4520c

The HWAM 4500-series

For more information on the HWAM 4500-series, see side 67.



HWAM 4520c
HWAM® Autopilot™



HWAM 4510c
on a low base
HWAM® Autopilot™



HWAM 4510c
on a low plinth
HWAM® Autopilot™



HWAM 4520m
on a high plinth



HWAM 4530c
with side glass



HWAM 4530m
with side glass



HWAM 4540c
with soapstone



HWAM 4550m
with side glass



HWAM 4560c



HWAM 4560m
with soapstone



Choose between
5 different types of
stone cladding**

For more information
see page 67

SLIGHTLY MORE EDGE

HWAM 4500 Design by Sørig & Jacobsen

Decorate your home with HWAM 4520, which oozes elegance and exclusivity, and let its attractive design contribute to a timeless Scandinavian look. This sophisticated wood-burning stove offers you an impressive view of the flames. A timeless wood-burning stove with excellent and clean combustion. For more information about the HWAM 4500-series, see page 67.



HWAM 4510m, low base

Technical data

Capacity
Nominal heat output
Smoke outlet
Energy efficiency class HWAM® Autopilot™/ HWAM® SmartControl™
Net efficiency HWAM® Autopilot™/ HWAM® SmartControl™
Right hinged door
Chimney draught, min. (recommended)
Width of combustion chamber

3-7 kW
4.9 kW
Ø 150 mm
A+ / **A+**
81.6/81.0%
Classic or modern
12 Pa
35.8 cm

Approvals & registrations

- EN 13240
- NS 3058/3059
- Art. 15a
- BImSchV Stufe 2
- LRV
- RLU
- Brændeovnsbekendtgørelsen 2018



* Only HWAM 4540 and 4560

Combustion air system



1) Not HWAM 4510 and 4520 when placed on the floor without a plinth



HWAM 4660c

The HWAM 4600-series

For more information on the HWAM 4600-series, see page 70.



HWAM 4620c



HWAM 4640m



HWAM 4640m with soapstone



HWAM 4660c



HWAM 4660m with Tobacco



Choose between
5 different types of
stone cladding

For more information
see page 70

WIDE & BREATHTAKING

HWAM 4600 Design by Sørig & Jacobsen

HWAM 4660 has a simple, architectural design with unique details-. The extra-wide HWAM 4600 models allow an even better view of the flames. The extra spacious combustion chamber allows firewood of up to 49 cm in length. Sit back and enjoy the flames for even longer. For more information about the HWAM 4600-series, see page 70.



Technical data

Capacity
Nominal heat output HWAM® Autopilot™/ HWAM® SmartControl™
Smoke outlet
Energy efficiency class HWAM® Autopilot™/ HWAM® SmartControl™
Net efficiency HWAM® Autopilot™/ HWAM® SmartControl™
Right hinged door
Chimney draught, min. (recommended)
Width of combustion chamber

3-9 kW
7.0/8.0 kW
Ø 150 mm
A / **A+**
80/81%
Classic or modern
12 Pa
49 cm

Approvals & registrations

- EN 13240
- NS 3058/3059
- Art. 15a
- BlmSchV Stufe 2
- LRV
- RLU
- Brændeovnsbekendtgørelsen 2018



* Not HWAM® SmartControl™

Combustion air system



A MODULAR STOVE TO YOUR TASTE

HWAM 5500 Design by Sørig & Jacobsen

Do you prefer one, two, three modules? Would you prefer just having the wood-burning stove module? Whatever the number of modules, the result is always the same: a stylish wood-burning stove of a modern Danish design. HWAM 5530 is the name of our new modular wood-burning stove. Whether you choose one or several modules, the stove will always appear as one integrated unit. The design is streamlined and functional. The sharp angles tell the story of Danish design and attention to detail. The functions are unmistakable. Keep your firewood in the modules or take a break and enjoy the heat. Add a stylish cushion on top of the side module to enjoy the heat and the crackling sounds close up. Choose high and/or low modules, with or without drawers. You decide! For more information on HWAM 5530, see page 72.



The HWAM 5500-series

For more information
on the HWAM 5530-series,
see page 72.





HWAM 5530m

Technical data

Capacity	4-8 kW
Nominal heat output HWAM® Autopilot™/ HWAM® SmartControl™	6.4/6.0 kW
Smoke outlet	Ø 150 mm
Energy efficiency class HWAM® Autopilot™/ HWAM® SmartControl™	A / A+
Net efficiency HWAM® Autopilot™/ HWAM® SmartControl™	80/83%
Door	Classic or modern
Left or right hinged door	
Chimney draught, min. (recommended) HWAM® Autopilot™/ HWAM® SmartControl™	1/12 Pa
Width of combustion chamber	62.7 cm

Approvals & registrations

- EN 13240
- NS 3058/3059
- Art. 15a
- BlmSchV Stufe 2
- LRV
- RLU
- Brændeovnsbekendtgørelsen 2018



Combustion air system





Optional fresh air kit to connect to external air

For more information see page 74

HWAM Classic 4

The HWAM Classic-series

For more information on the HWAM Classic-series, see page 74.



HWAM Classic 4



HWAM Classic 4 with wood store



HWAM Classic 4 with wood store and baking oven



WE LOVE THE CLASSICS

HWAM Classic 4 Design by Anders C. Fasterholdt

HWAM Classic 4 is a classic stove that has been very popular ever since it saw the light of day more than 30 years ago. The HWAM Classic 4 series is available in different versions. The basic stove has hobs for heating food. You can add a handy baking oven, that makes it possible to utilize the heat to bake pizzas, bread, and pastries. Enjoy the smell of freshly baked bread spreading to the house while you enjoy a quiet moment in front of the dancing flames. By adding a plinth, you can store your wood underneath the wood-burning stove – decorative and practical. As something new we can offer fresh air system for this oven. Who could ask for more? For more information about the HWAM Classic-series, see page 74.



HWAM Classic 4 with wood store

Technical data

Capacity	3-8 kW
Nominal heat output	8.0 kW
Smoke outlet	Ø 150 mm
Energy efficiency class	A
Net efficiency	79.3%
Right hinged door	Classic
Chimney draught, min. (recommended)	12 Pa
Width of combustion chamber	40 cm

Capacity	3-8 kW
Nominal heat output	8.0 kW
Smoke outlet	Ø 150 mm
Energy efficiency class	A
Net efficiency	79.3%
Right hinged door	Classic
Chimney draught, min. (recommended)	12 Pa
Width of combustion chamber	40 cm

Approvals & registrations

- EN 13240
- BlmSchV Stufe 2
- LRV



Combustion air system





HWAM I 40/55c

HWAM I 40/55

For more information on HWAM I 40/55, see page 75.



Standard

Standard measures. This frame is integrated as standard if no customised frame is chosen.



Without bent edges

3 mm thick flat frame without bent edges. Made with customised measures with or without sides.



With bent edges

Frame with bent edges. Made with customised measures with or without sides.



In-built depth of 35 cm

Standard measures. With this frame an in-built depth of 35 cm is achieved.



AN INTEGRATED PART OF YOUR HOME

HWAM I 40/55 Design by Sørig & Jacobsen

Simple elegance, clean lines and a minimalist design characterise our new insert, HWAM I 40/55. The wide glass offers a spectacular view of the dancing flames and plays a prominent role by virtue of the simple design. This model is available with a classic cast iron door or a modern glass door, and you can choose between a right hinged or a left hinged door. HWAM I 40/55 has been designed to allow for very easy servicing. The wide combustion chamber is mounted on a rotary arm, which means that the stove can easily be swivelled into the room to allow easy access to all its parts. When you buy a HWAM I 40/55 insert, you have the option of buying various types of customised frames. A frame without bent edges is both stylish and eye-catching. For more information about HWAM I 40/55, see page 75.



HWAM I 40/55m

Technical data

Capacity	4-8 kW
Nominal heat output HWAM® Autopilot™ / HWAM® SmartControl™	6.4/6.0 kW
Smoke outlet	Ø 150 mm
Energy efficiency class HWAM® Autopilot™ / HWAM® SmartControl™	A / A+
Net efficiency HWAM® Autopilot™ / HWAM® SmartControl™	80/83%
Door	Classic or modern
Left or right hinged door	
Chimney draught, min. (recommended) HWAM® Autopilot™ / HWAM® SmartControl™	1/12 Pa
Width of combustion chamber	62.7 cm

Approvals & registrations

- EN 13229
- NS 3058/3059
- Art. 15a
- BlmSchV Stufe 2
- LRV
- RLU
- Brændeovnsbekendtgørelsen 2018



Combustion air system



HWAM ACCESSORIES

Complete your HWAM wood-burning stove with accessories. A beautiful floor plate to match your choice of model perfectly or a practical and sculptural way of storing your firewood? Prolong the warmth of the fire with heat storing stones or have fresh air supplied from the outside for better combustion and a better indoor climate.

Firewood box

A HWAM Firewood box is a practical and robust helper when you transport firewood to your wood-burning stove. Thanks to its large wheels and a sturdy handle, it is easy to push the box, even when filled with wood. The design is elegant and matches all our stoves.

Firewood bucket

A classic and robust firewood bucket that will look decorative next to your wood-burning stove.

Wall-mounted firewood storage

If you want to keep your floor space, our round firewood storage solution will do the trick. Available in various sizes.

Floor plates

A tailor-made floor plate is available for most of our wood-burning stove models. We have developed floor plates in steel and glass adapted to the shape of your wood-burning stove. Aesthetically, the plates will match any interior design style, and they are easy to remove for cleaning purposes.

Heat storing stone

Selected HWAM models are designed with a heat storage compartment that can be filled with heat storing stone. This type of stone has a special ability to store the heat from the stove and slowly release it into the room. This means that you can enjoy the heat long after the fire has gone out. The models appear from the product overview on page 76.

Fresh air system

Many new or newly renovated houses are so well isolated that they may prevent the supply of combustion air from the room. As a consequence, the wood-burning stove will be lacking air. This may be remedied by connecting a fresh-air system to your wood-burning stove.



Wall-mounted firewood storage

Available in grey or black.
Ø 42,2 cm. D 27 or 35 cm
Ø 60 cm. D 27 or 35 cm

SmartBackup

The battery module, SmartBackup, is purchased separately and is easy to install on the HWAM SmartControl™ system. We have developed this so we can offer you perfect security in relation to our technological system. We want it to be as easy and secure as possible for you to take advantage of technological combustion control in your HWAM stove. The battery means you are not dependent on the power supply, if there is a power outage.





Firewood box

H 87,5 B 50,5 D 38,5 cm



Firewood bucket

H 30,0 x Ø 42,8 cm
W incl. handle: 48,6 cm



Floor plates

Available in glass or steel.
Adapted to the shape of
your wood-burning stove.



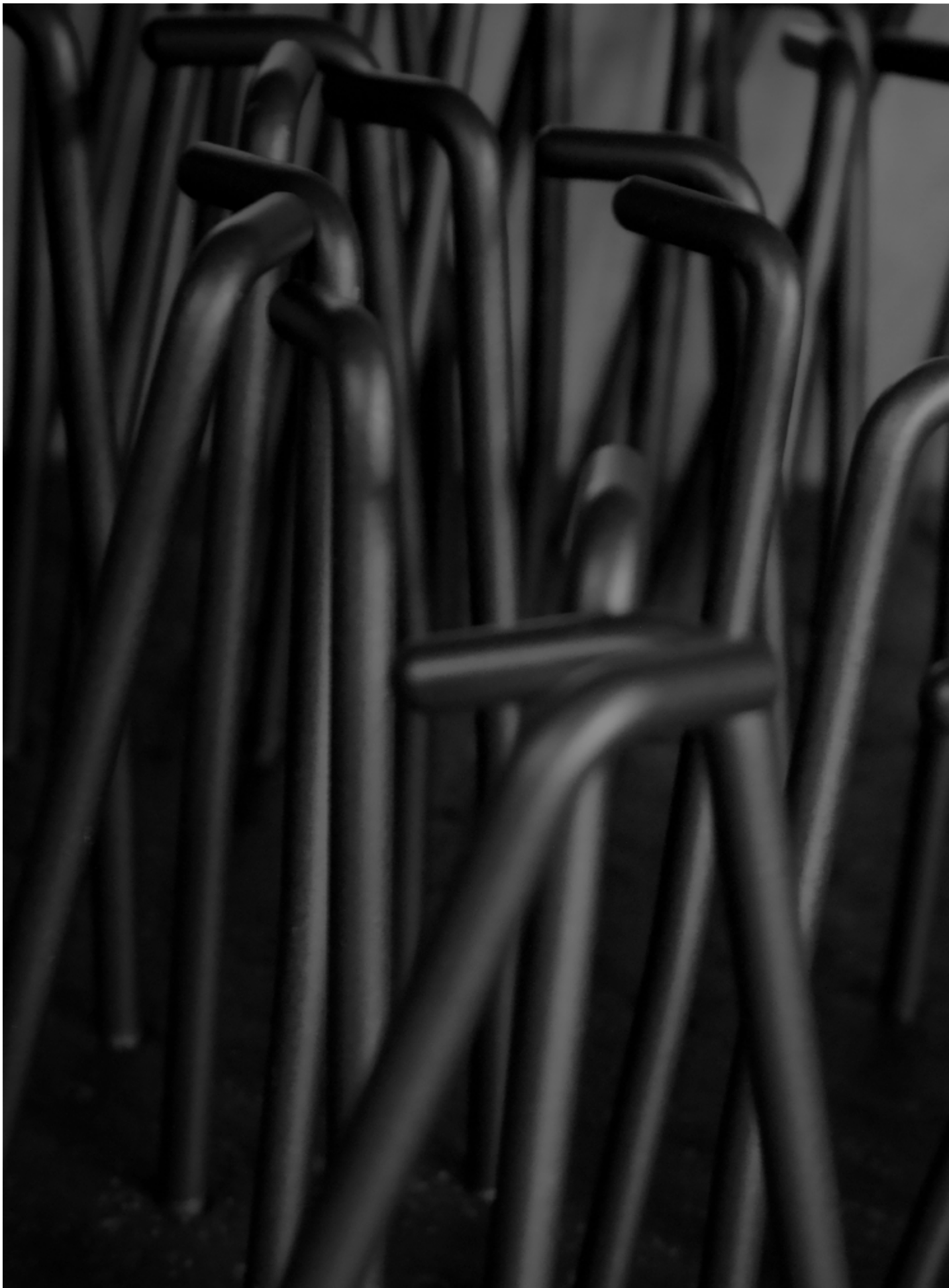

TECHNICAL SPECIFICATIONS

52	HWAM 2600
54	HWAM 3100
56	HWAM 3500
57	HWAM 3600
60	HWAM 3700
62	HWAM 4100
65	HWAM 4200
66	HWAM 4300
67	HWAM 4500
70	HWAM 4600
72	HWAM 5530
74	HWAM Classic 4
75	HWAM I 40/55
76	Product overview
78	Distance to combustible materials
80	Test results
82	Approvals & registrations

HWAM 2610/2620

Technical data

Capacity	2-6 kW
Nominal heat output	4.5 kW
Smoke outlet	Ø 150 mm
Net efficiency	80.3%
Chimney draught, min. (recommended)	12 Pa
Energy efficiency class	A

Weight

Weight HWAM 2610c/2610m	66/64 kg
Weight HWAM 2620c/2620m	66/64 kg
Weight pedestal	15 kg

Measurements

Width of combustion chamber	27.0 cm
Connection from floor*, top	65.1 cm
Connection from floor on a plinth, top	68.1 cm
Connection from floor on a pedestal, top	95.1 cm
Connection from wall to center of top outlet, wall mounted	18.9 cm

* From the lower edge of the stove without plinth

Variants

- Autopilot™
- Classic door (c) or modern door (m)
- Cast iron top, top outlet or back outlet
- Pedestal, plinth or wall mounted
- HWAM 2610m/2620m are available in black, grey and white
- HWAM 2610c/2620c are available in black and grey

Accessories

Combustion air system, rear/bottom

Approvals and registrations

- EN 13240
- NS 3058/3059
- BlmSchV Stufe 2
- LRV
- Brændeovnsbekendtgørelsen 2018



Combustion air system



HWAM 2610c with side glass and on a plinth



HWAM 2610m with side glass



HWAM 2620c on a pedestal

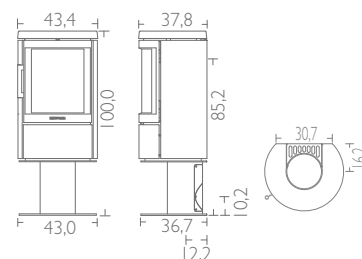
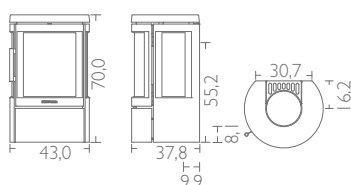
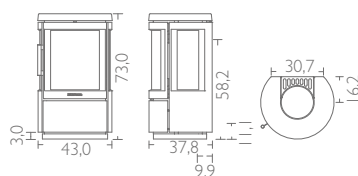

All drawings: The measurements for the flue outlet and fresh air connection are to the centre of the hole.



HWAM 2630/2640

Technical data

Capacity	2-6 kW
Nominal heat output	4.5 kW
Smoke outlet	Ø 150 mm
Net efficiency	80.3%
Chimney draught, min. (recommended)	12 Pa
Energy efficiency class	A

Weight

Weight HWAM 2630c/2630m	75/73 kg
Weight HWAM 2640c/2640m	75/73 kg

Measurements

Width of combustion chamber	27.0 cm
Connection from floor, top	95.1 cm

Variants

- Autopilot™
- Classic door (c) or modern door (m)
- Cast iron top, top outlet or back outlet
- HWAM 2630m/2640m are available in black, grey and white
- HWAM 2630c//2640c are available in black and grey

Accessories

Combustion air system, rear/bottom

Approvals and registrations

- EN 13240
- NS 3058/3059
- BImSchV Stufe 2
- LRV
- RLU
- Brændeovnsbekendtgørelsen 2018



Combustion air system



HWAM 2630c with side glass



HWAM 2640c



HWAM 2640m

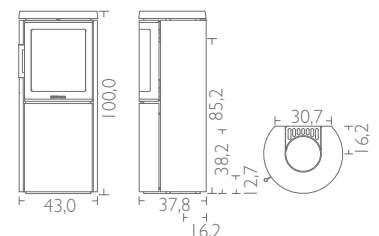
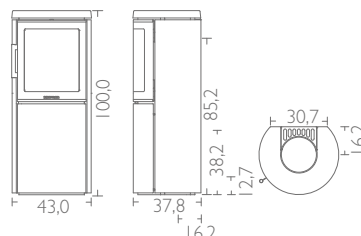
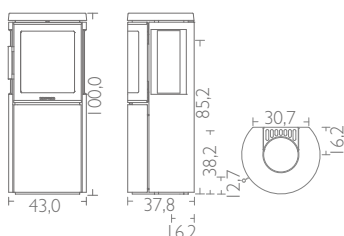

HWAM 3110

Technical data

Capacity	2-7 kW
Nominal heat output	4.5 kW
Smoke outlet	Ø 150 mm
Net efficiency Autopilot™	78.1%
Chimney draught, min. (recommended)	12 Pa
Energy efficiency class	A

Weight

Weight HWAM 3110c/3110m	87/84 kg
Weight, pedestal	14 kg

Measurements

Width of combustion chamber	33.0 cm
Connection from floor*, top	69.8 cm
Connection from floor on a plinth, top	72.8 cm
Connection from floor on a pedestal, top	99.8 cm
Connection from wall to center of top outlet, wall-mounted	20.5 cm

* From the lower edge of the stove without plinth

Variants

Autopilot™
Classic door (c) or modern door (m)
Traditional handle (stainless steel) or style handle (stainless steel or black)
Cast iron top, top outlet or back outlet
Pedestal, plinth, wall bracket or corner wall bracket
HWAM 3110m is available in black, grey and white
HWAM 3110c is available in black and grey

Accessories

Combustion air system, rear/bottom

Approvals and registrations

- EN 13240
- NS 3058/3059
- BlmSchV Stufe 2
- LRV
- Brændeovnsbekendtgørelsen 2018



Combustion air system



HWAM 3110c on a plinth
Traditional handle



HWAM 3110m, white
Traditional handle



HWAM 3110c on a pedestal
Style handle (black)



Traditional handle



Style handle
(stainless steel)



Style handle
(black)

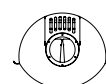
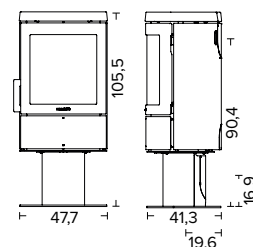
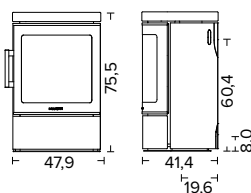
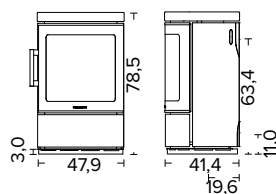



HWAM 3120/3130

Technical data

Capacity	2-7 kW
Nominal heat output	4.5 kW
Smoke outlet	Ø 150 mm
Net efficiency Autopilot™/ SmartControl™	78.1/83.4%
Chimney draught, min. (recommended)	12 Pa
Energy efficiency class Autopilot™/SmartControl™	A/A+

Weight

Weight HWAM 3120c/3120m	107/104 kg
Weight HWAM 3130c/3130m	113/110 kg
Weight, heat storage stones	Ca. 32 kg

Measurements

Width of combustion chamber	33.0 cm
Connection from floor with Autopilot™, top	94.8 cm
Connection from floor with SmartControl™, top	97.5 cm

* Only HWAM® SmartControl™
** Only HWAM 3120 Autopilot™

Variants

- Autopilot™ or SmartControl™
- Classic door (c) or modern door (m)
- Traditional handle (stainless steel) or style handle (stainless steel or black)
- Cast iron top, top outlet or back outlet
- HWAM 3120m/3130m are available in black, grey and white
- HWAM 3120c/3130c are available in black and grey

Accessories

- Combustion air system, rear/bottom
- Heat storage stones (HWAM 3130)

Approvals and registrations

- EN 13240
- NS 3058/3059
- Art. 15a*
- BImSchV Stufe 2
- LRV
- RLU
- Brændeovnsbekendtgørelsen 2018



Combustion air system



HWAM 3120c
Style handle (stainless steel)



HWAM 3120m, white
Traditional handle



HWAM 3130m
Traditional handle

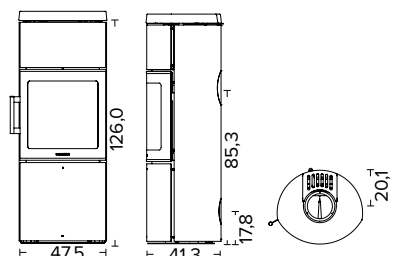
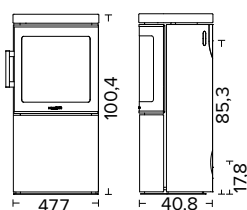
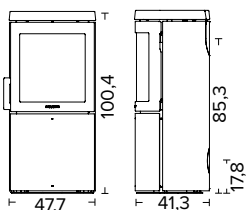

HWAM 3520

Technical data

Capacity	2-7 kW
Nominal heat output	4.5 kW
Smoke outlet	Ø 150 mm
Net efficiency Autopilot™/SmartControl™	78.1/83.4%
Chimney draught, min. (recommended)	12 Pa
Energy efficiency class Autopilot™/SmartControl™	A/A+

Weight

Weight HWAM 3520c/3520m	118/115 kg
Weight with soapstone cladding HWAM 3520c/3520m	167/164 kg
Weight with natural stone cladding HWAM 3520c/3520m	155/152 kg
Weight, heat storage stones	Ca. 44 kg

Measurements

Width of combustion chamber	33.0 cm
Connection from floor with Autopilot™, top	95.0 cm
Connection from floor with SmartControl™, top	97.7 cm

* Not HWAM® Autopilot™

** Not HWAM® SmartControl™

Variants

Autopilot™ or SmartControl™
Classic door (c) or modern door (m)
Traditional handle (stainless steel) or style handle (stainless steel or black)
Cast iron top, top outlet or back outlet
Soapstone cladding, top outlet or back outlet
Natural stone cladding, top outlet or back outlet
HWAM 3520m is available in black, grey and white
HWAM 3520c is available in black and grey
HWAM 3520 with stone cladding is available in black and grey

Accessories

Combustion air system, rear/bottom
Heat storage stones

Approvals and registrations

- EN 13240
- NS 3058/3059
- Art. 15a*
- BlmSchV Stufe 2
- LRV
- RLU
- Brændeovnsbekendtgørelsen 2018



Combustion air system



HWAM 3520c
Style handle (stainless steel)



HWAM 3520m
Traditional handle



HWAM 3520c with soapstone cladding
Traditional handle

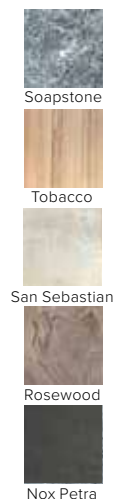

Traditional handle



Style handle
(stainless steel)



Style handle
(black)

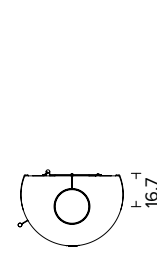
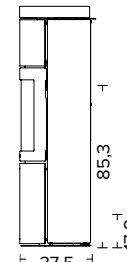
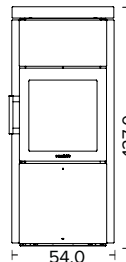
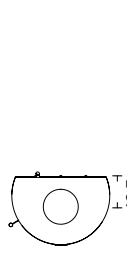
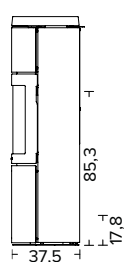
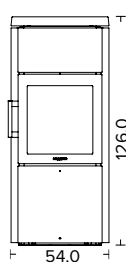
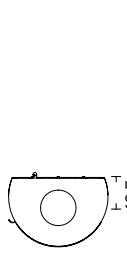
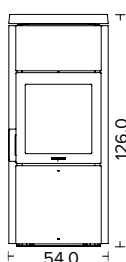



HWAM 3630/3640

Technical data

Capacity	3-9 kW
Nominal heat output	6.0 kW
Smoke outlet	Ø 150 mm
Net efficiency Autopilot™/SmartControl™	78.3/80.7%
Chimney draught, min. (recommended) Autopilot™/SmartControl™	11/12 Pa
Energy efficiency class Autopilot™/SmartControl™	A/A+

Weight

Weight HWAM 3630c/3630m	139/136 kg
Weight HWAM 3640c/3640m	139/136 kg
Weight with soapstone cladding HWAM 3640c/3640m	229/226 kg
Weight with natural stone cladding HWAM 3640c/3640m	211/208 kg

Measurements

Width of combustion chamber	38.0 cm
Connection from floor with Autopilot™, top	109.6 cm
Connection from floor with SmartControl™, top	112.3 cm

* Not HWAM® Autopilot™

** Not HWAM® SmartControl™

Variants

- Autopilot™ or SmartControl™
- Classic door (c) or modern door (m)
- Cast iron top, top outlet or back outlet
- Soapstone cladding, top outlet or back outlet (HWAM 3640)
- Natural stone cladding, top outlet or back outlet (HWAM 3640)
- HWAM 3630m/3640m are available in black, grey and white
- HWAM 3630c/3640c are available in black and grey
- HWAM 3640 with stone cladding is available in black and grey

Accessories

Combustion air system, rear/bottom

Approvals and registrations

- EN 13240
- NS 3058/3059
- Art. 15a*
- BImSchV Stufe 2
- LRV
- RLU
- Brændeovnsbekendtgørelsen 2018



Combustion air system



HWAM 3630c with side glass



HWAM 3640m, white



HWAM 3640c with soapstone cladding

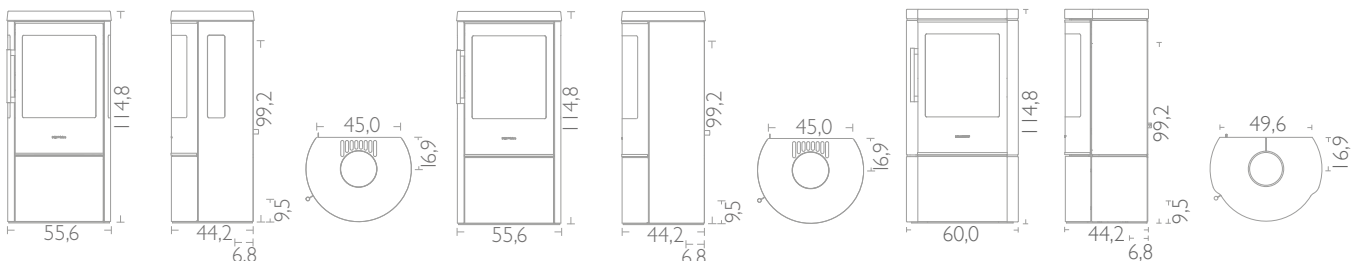
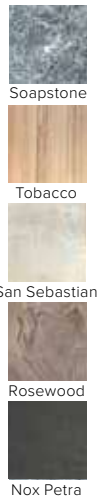

All drawings: The measurements for the flue outlet and fresh air connection are to the centre of the hole.

HWAM 3650

Technical data

Capacity	3-9 kW
Nominal heat output	6.0 kW
Smoke outlet	Ø 150 mm
Net efficiency Autopilot™/ SmartControl™	78.3/80.7%
Chimney draught, min. (recommended) Autopilot™/SmartControl™	11/12 Pa
Energy efficiency class Autopilot™/SmartControl™	A/A+

Weight

Weight HWAM 3650c/3650m	171/168 kg
Weight, heat storage stones	Ca. 55 kg

Measurements

Width of combustion chamber	38.0 cm
Connection from floor with Autopilot™, top	109.6 cm
Connection from floor with SmartControl™, top	112.3 cm

* Not HWAM® Autopilot™

** Not HWAM® SmartControl™

Variants

- Autopilot™ or SmartControl™
- Classic door (c) or modern door (m)
- Cast iron top, top outlet or back outlet
- HWAM 3650m is available in black, grey and white
- HWAM 3650c is available in black and grey

Accessories

- Combustion air system, rear/bottom
- Heat storage stones

Approvals and registrations

- EN 13240
- NS 3058/3059
- Art. 15a*
- BImSchV Stufe 2
- LRV
- RLU
- Brændeovnsbekendtgørelsen 2018



Combustion air system



HWAM 3650c with side glass



HWAM 3650m with side glass, white

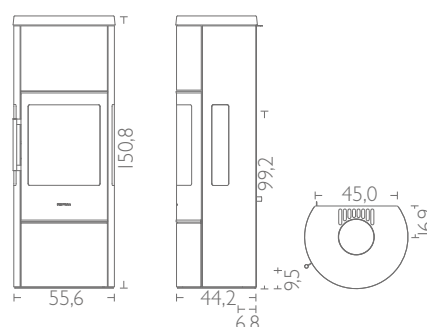
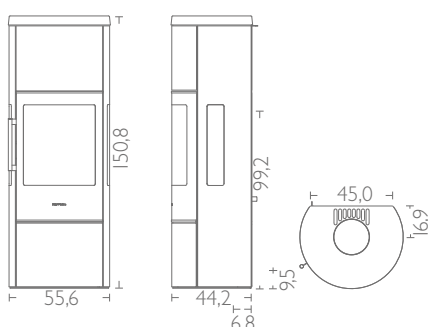



HWAM 3660

Technical data

Capacity	3-9 kW
Nominal heat output	6.0 kW
Smoke outlet	Ø 150 mm
Net efficiency Autopilot™/SmartControl™	78.3/80.7%
Chimney draught, min. (recommended) Autopilot™/SmartControl™	11/12 Pa
Energy efficiency class Autopilot™/SmartControl™	A/A+

Weight

Weight HWAM 3660c/3660m	171/168 kg
Weight with soapstone cladding HWAM 3660c/3660m	282/279 kg
Weight with natural stone cladding HWAM 3660c/3660m	260/257 kg
Weight, heat storage stones	Ca. 55 kg

Measurements

Width of combustion chamber	38.0 cm
Connection from floor with Autopilot™, top	109.6 cm
Connection from floor with SmartControl™, top	112.3 cm

* Not HWAM® Autopilot™

** Not HWAM® SmartControl™

Variants

- Autopilot™ or SmartControl™
- Classic door (c) or modern door (m)
- Cast iron top, top outlet or back outlet
- Soapstone cladding, top outlet or back outlet
- Natural stone cladding, top outlet or back outlet
- HWAM 3660m is available in black, grey and white
- HWAM 3660c is available in black and grey
- HWAM 3660 with stone cladding is available in black and grey

Accessories

- Combustion air system, rear/bottom
- Heat storage stones

Approvals and registrations

- EN 13240
- NS 3058/3059
- Art. 15a*
- BlmSchV Stufe 2
- LRV
- RLU
- Brændeovnsbekendtgørelsen 2018



Combustion air system



HWAM 3660c



HWAM 3660m, white



HWAM 3660m with soapstone cladding

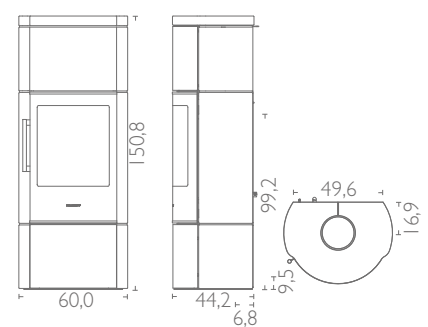
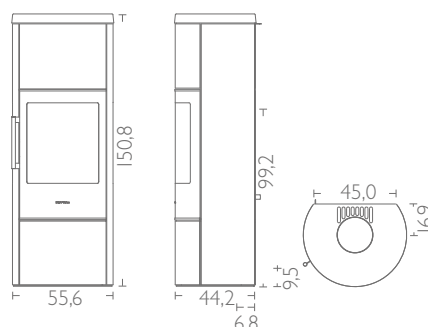
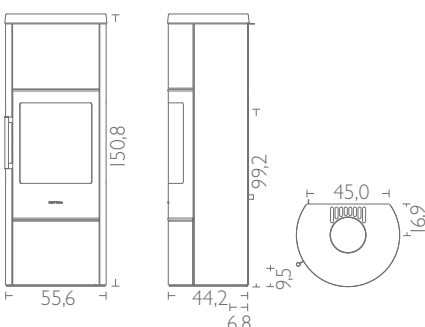
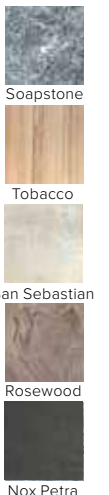

All drawings: The measurements for the flue outlet and fresh air connection are to the centre of the hole.

HWAM 3740

Technical data

Capacity	2-7 kW
Nominal heat output	4.5 kW
Smoke outlet	Ø 150 mm
Net efficiency Autopilot™/ SmartControl™	78.1/83.4%
Chimney draught, min. (recommended)	12 Pa
Energy efficiency class Autopilot™/SmartControl™	A/A+

Weight

Weight HWAM 3740c/3740m	104/101 kg
-------------------------	------------

Measurements

Width of combustion chamber	33.0 cm
Connection from floor with Autopilot™, top	94.8 cm
Connection from floor with SmartControl™, top	97.5 cm

* Only HWAM® SmartControl™

Variants

- Autopilot™ or SmartControl™
- Classic door (c) or modern door (m)
- Open or closed top (top outlet or back outlet)
- Traditional handle (stainless steel) or style handle (stainless steel or black)
- HWAM 3740c/3740m are available in black and grey

Accessories

Combustion air system, rear/bottom

Approvals and registrations

- EN 13240
- NS 3058/3059
- Art. 15a*
- BlmSchV Stufe 2
- LRV
- Brændeovnsbekendtgørelsen 2018



Combustion air system



HWAM 3740c
Traditional handle



HWAM 3740c
Style handle (stainless steel)



HWAM 3740m
Style handle (black)

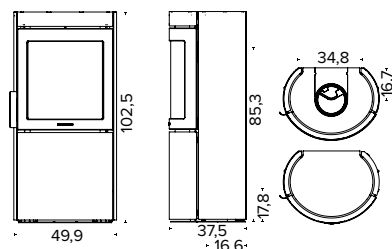

All drawings: The measurements for the flue outlet and fresh air connection are to the centre of the hole.



HWAM 3760

Technical data

Capacity	2-7 kW
Nominal heat output	4.5 kW
Smoke outlet	Ø 150 mm
Net efficiency Autopilot™/ SmartControl™	78.1/83.4%
Chimney draught, min. (recommended)	12 Pa
Energy efficiency class Autopilot™/SmartControl™	A/A+

Weight

Weight HWAM 3760c/3760m	117/113 kg
Weight, heat storing stones	Ca. 32 kg

Measurements

Width of combustion chamber	33.0 cm
Connection from floor with Autopilot™, top	94.8 cm
Connection from floor with SmartControl™, top	97.5 cm

* Only HWAM® SmartControl™

Variants

- Autopilot™ or SmartControl™
- Classic door (c) or modern door (m)
- Open or closed top (top outlet or back outlet)
- Traditional handle (stainless steel) or style handle (stainless steel or black)
- HWAM 3740c/3740m are available in black and grey

Accessories

- Combustion air system, rear/bottom
- Heat storage stones

Approvals and registrations

- EN 13240
- NS 3058/3059
- Art. 15a*
- BlmSchV Stufe 2
- LRV
- Brændeovnsbekendtgørelsen 2018



Combustion air system



HWAM 3760m
Traditional handle



HWAM 3760c
Style handle (stainless steel), grey



HWAM 3760c
Style handle (black)

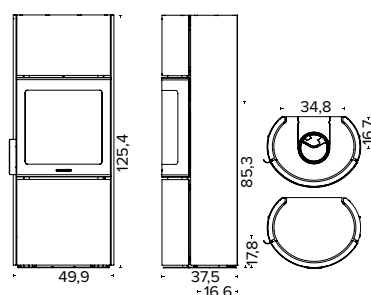

All drawings: The measurements for the flue outlet and fresh air connection are to the centre of the hole.

HWAM 4110/4120

Technical data

Capacity	2-7 kW
Nominal heat output Autopilot™/ SmartControl™	4.7/4.9 kW
Smoke outlet	Ø 150 mm
Net efficiency Autopilot™/ SmartControl™	82/86%
Chimney draught, min. (recommended)	12 Pa
Energy efficiency class Autopilot™/SmartControl™	A+/A+

Weight

Weight HWAM 4110/4120	142/140 kg
-----------------------	------------

Measurements

Width of combustion chamber	28.4-35.8 cm
Connection from floor, top	95.9 cm

Variants

- Autopilot™ or SmartControl™
- Open or closed top (top outlet or back outlet)
- Left hinged door
- HWAM 4110/4120 are available in black and grey

Accessories

- Combustion air system, rear/bottom

Approvals and registrations

- EN 13240
- NS 3058/3059
- Art. 15a
- BImSchV Stufe 2
- LRV
- Brændeovnsbekendtgørelsen 2018



Combustion air system



HWAM 4110 with side glass



HWAM 4120, grey



Closed top (back outlet)



Open top (top outlet)

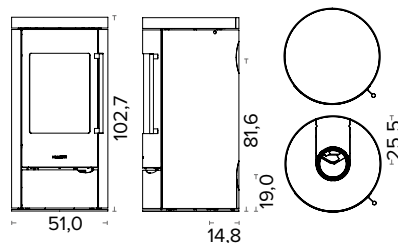
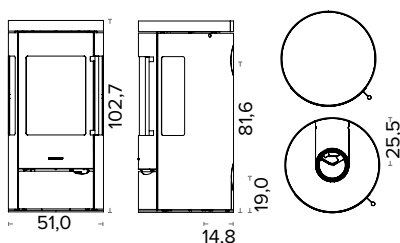



HWAM 4130/4140

Technical data

Capacity	2-7 kW
Nominal heat output Autopilot™/ SmartControl™	4.7/4.9 kW
Smoke outlet	Ø 150 mm
Net efficiency Autopilot™/ SmartControl™	82/86%
Chimney draught, min. (recommended)	12 Pa
Energy efficiency class Autopilot™/SmartControl™	A+/A+

Weight

Weight HWAM 4130/4140	158/156 kg
-----------------------	------------

Measurements

Width of combustion chamber	28.4-35.8 cm
Connection from floor, top	112.6 cm

Variants

- Autopilot™ or SmartControl™
- Open or closed top (top outlet or back outlet)
- Left hinged door
- HWAM 4130/4140 are available in black and grey

Accessories

- Combustion air system, rear/bottom

Approvals and registrations

- EN 13240
- NS 3058/3059
- Art. 15a
- BImSchV Stufe 2
- LRV
- Brændeovnsbekendtgørelsen 2018



Combustion air system



HWAM 4130 with side glass



HWAM 4140, grey



Closed top (back outlet)



Open top (top outlet)

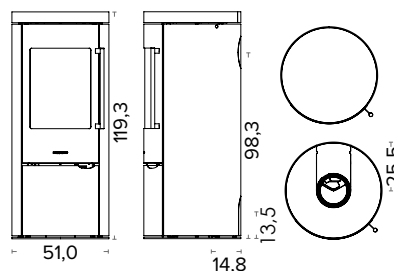
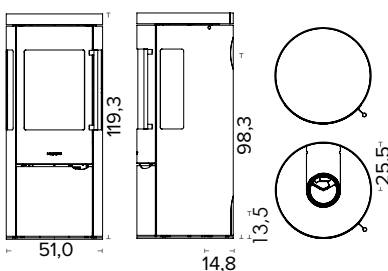

HWAM 4150/4160

Technical data

Capacity	2-7 kW
Nominal heat output Autopilot™/ SmartControl™	4.7/4.9 kW
Smoke outlet	Ø 150 mm
Net efficiency Autopilot™/ SmartControl™	82/86%
Chimney draught, min. (recommended)	12 Pa
Energy efficiency class Autopilot™/SmartControl™	A+/A+

Weight

Weight HWAM 4150/4160	171/169 kg
Weight, heat storage stones	Ca. 30, 60 or 90 kg

Measurements

Width of combustion chamber	28.4-35.8 cm
Connection from floor, top	112.6 cm

Variants

- Autopilot™ or SmartControl™
- Open or closed top (top outlet or back outlet)
- Left hinged door
- HWAM 4150/4160 are available in black and grey

Accessories

- Combustion air system, rear/bottom
- Heat storage stones

Approvals and registrations

- EN 13240
- NS 3058/3059
- Art. 15a
- BImSchV Stufe 2
- LRV
- Brændeovnsbekendtgørelsen 2018



Combustion air system



HWAM 4150 with side glass



HWAM 4160, grey



Closed top (back outlet)



Open top (top outlet)

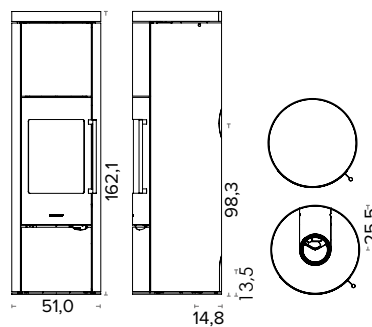
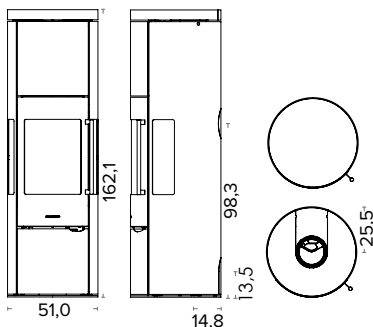



HWAM 4240

Technical data

Capacity	2-7 kW
Nominal heat output Autopilot™/ SmartControl™	4.7/4.9 kW
Smoke outlet	Ø 150 mm
Net efficiency Autopilot™/ SmartControl™	82/86%
Chimney draught, min. (recommended)	12 Pa
Energy efficiency class Autopilot™/SmartControl™	A+/A+

Weight

Weight	135 kg
Weight with soapstone cladding	215 kg
Weight with natural stone cladding	191 kg

Measurements

Width of combustion chamber	28.4-35.8 cm
Connection from floor, top	107.7 cm

Variants

- Autopilot™ or SmartControl™
- Steel top, top outlet or back outlet
- Soapstone cladding, top outlet or back outlet
- Natural stone cladding, top outlet or back outlet
- Left hinged door
- HWAM 4240 is available in black and grey
- HWAM 4240 with stone cladding is available in black and grey

Accessories

- Combustion air system, rear/bottom

Approvals and registrations

- EN 13240
- NS 3058/3059
- Art. 15a
- BImSchV Stufe 2
- LRV
- Brændeovnsbekendtgørelsen 2018



Combustion air system



HWAM 4240



HWAM 4240
with soapstone cladding

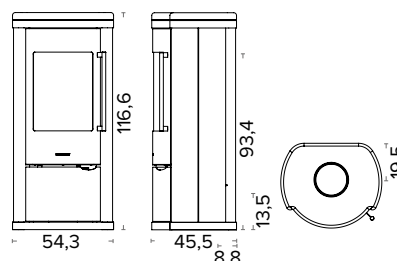
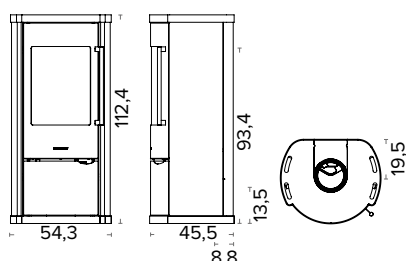
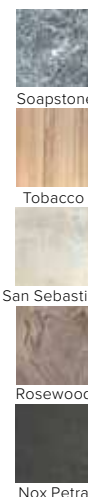

All drawings: The measurements for the flue outlet and fresh air connection are to the centre of the hole.

HWAM 4340

Technical data

Capacity	3-8 kW
Nominal heat output	6.0 kW
Smoke outlet	Ø 150 mm
Net efficiency Autopilot™/ SmartControl™	80/82%
Chimney draught, min. (recommended)	12 Pa
Energy efficiency class Autopilot™/SmartControl™	A/A+

Weight

Weight	140 kg
Weight with soapstone cladding	227 kg
Weight with natural stone cladding	198 kg

Measurements

Width of combustion chamber	38.2 cm
Connection from floor, top	115.1 cm

Variants

- Autopilot™ or SmartControl™
- Steel top, top outlet or back outlet
- Soapstone cladding, top outlet or back outlet
- Natural stone cladding, top outlet or back outlet
- Left hinged door
- HWAM 4340 is available in black and grey
- HWAM 4340 with stone cladding is available in black and grey

Accessories

Combustion air system, rear/bottom

Approvals and registrations

- EN 13240
- NS 3058/3059
- Art. 15a
- BlmSchV Stufe 2
- LRV
- Brændeovnsbekendtgørelsen 2018



HWAM 4340



HWAM 4340
with natural stone cladding, Rosewood

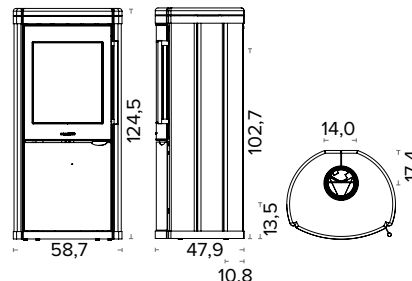
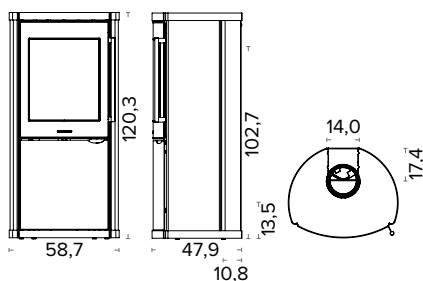
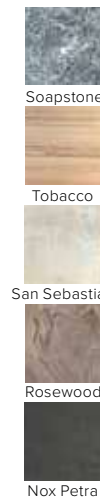

HWAM 4510/4520

Technical data

Capacity	3-7 kW
Nominal heat output	4.9 kW
Smoke outlet	Ø 150 mm
Net efficiency Autopilot™/ SmartControl™	82/81%
Chimney draught, min. (recommended)	12 Pa
Energy efficiency class Autopilot™/SmartControl™	A+/A+

Weight

Weight HWAM 4510c/4510m	101/99 kg
Weight HWAM 4520c/4520m	96/94 kg
Weight on a low base HWAM 4510c/4510m	103/101 kg
Weight on a low base HWAM 4520c/4520m	98/86 kg
Weight on a low plinth HWAM 4510c/4510m	105/103 kg
Weight on a low plinth HWAM 4520c/4520m	100/98 kg
Weight on a high plinth HWAM 4510c/4510m	109/107 kg
Weight on a high plinth HWAM 4520c/4520m	104/102 kg

Measurements

Width of combustion chamber	35.8 cm
Connection from floor without plinth, top, Autopilot™*	72.3 cm
Connection from floor without plinth, top, SmartControl™*	77.8 cm
Connection from floor low base, top	77.8 cm
Connection from floor low plinth, top	89.8 cm
Connection from floor high plinth, top	100.8 cm
Connection from wall to center of top outlet, wall mounted	21.3 cm

* From the lower edge of the stove.

NB: Do not place low models of HWAM 4510/4520 on a flammable floor. Ask your local retailer for advise if in doubt.

Variants

- Autopilot™ or SmartControl™ (only wall mounted or on a plinth)
- Classic door (c) or modern door (m)
- Cast iron top, top outlet or back outlet
- Floor model, low base, low plinth, high plinth or wall mounted
- HWAM 4510m/4520m are available in black, grey and white
- HWAM 4510c/4520c are available in black and grey

Accessories

- Combustion air system, rear/bottom

Approvals and registrations

- EN 13240
- NS 3058/3059
- Art. 15a
- BlmSchV Stufe 2
- LRV
- RLU
- Brændeovnsbekendtgørelsen 2018



Combustion air system



HWAM 4520c
HWAM® Autopilot™



HWAM 4510c
on a low base
HWAM® Autopilot™



HWAM 4510c
on a low plinth
HWAM® Autopilot™



HWAM 4520m
on a high plinth

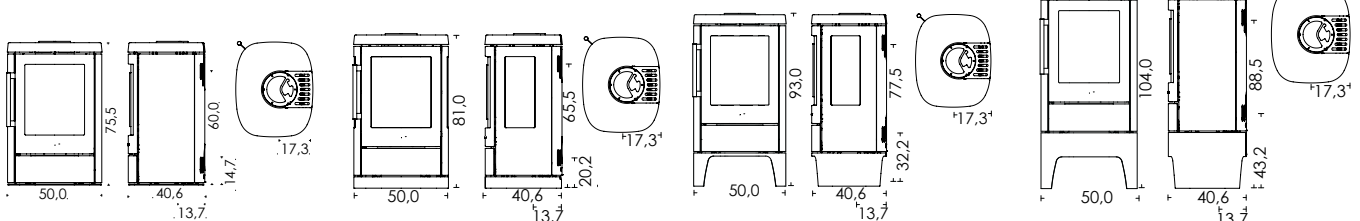

All drawings: The measurements for the flue outlet and fresh air connection are to the centre of the hole.

HWAM 4530/4540

Technical data

Capacity	3-7 kW
Nominal heat output	4.9 kW
Smoke outlet	Ø 150 mm
Net efficiency Autopilot™/ SmartControl™	82/81%
Chimney draught, min. (recommended)	12 Pa
Energy efficiency class Autopilot™/SmartControl™	A+/A+

Weight

Weight HWAM 4530c/4530m	124/122 kg
Weight HWAM 4540c/4540m	119/117 kg
Weight with soapstone cladding HWAM 4540c/4540m	175/173 kg
Weight with natural stone cladding HWAM 4540c/4540m	136/134 kg

Measurements

Width of combustion chamber	35.8 cm
Connection from floor, top	111.4 cm

* Only HWAM 4540

Variants

- Autopilot™ or SmartControl™
- Classic door (c) or modern door (m)
- Cast iron top, top outlet or back outlet
- Soapstone cladding, top outlet or back outlet (HWAM 4540)
- Natural stone cladding, top outlet or back outlet (HWAM 4540)
- HWAM 4530m/4540m are available in black, grey and white
- HWAM 4530c/4540c are available in black and grey
- HWAM 4540 with stone cladding is available in black and grey

Accessories

Combustion air system, rear/bottom

Approvals and registrations

- EN 13240
- NS 3058/3059
- Art. 15a
- BlmSchV Stufe 2
- LRV
- RLU
- Brændeovnsbekendtgørelsen 2018



Combustion air system



HWAM 4530c with side glass



HWAM 4540m



HWAM 4540c with soapstone cladding

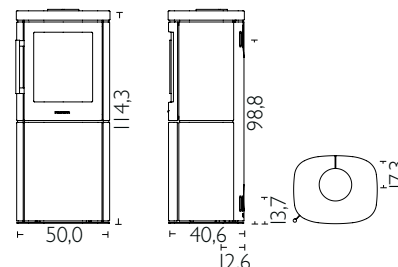
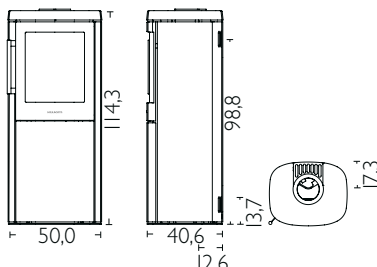
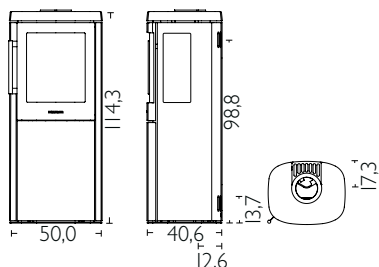
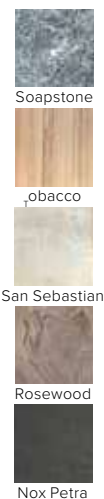

All drawings: The measurements for the flue outlet and fresh air connection are to the centre of the hole.



HWAM 4550/4560

Technical data

Capacity	3-7 kW
Nominal heat output	4.9 kW
Smoke outlet	Ø 150 mm
Net efficiency Autopilot™/SmartControl™	82/81%
Chimney draught, min. (recommended)	12 Pa
Energy efficiency class Autopilot™/SmartControl™	A+/A+

Weight

Weight HWAM 4550c/4550m	134/132 kg
Weight HWAM 4560c/4560m	129/127 kg
Weight with soapstone cladding HWAM 4560c/4560m	201/199 kg
Weight with natural stone cladding HWAM 4560c/4560m	156/154 kg
Weight, heat storage stones	Ca. 29 kg

Measurements

Width of combustion chamber	35.8 cm
Connection from floor, top	111.4 cm

* Only HWAM 4560

Variants

- Autopilot™ or SmartControl™
- Classic door (c) or modern door (m)
- Cast iron top, top outlet or back outlet
- Soapstone cladding, top outlet or back outlet (HWAM 4560)
- Natural stone cladding, top outlet or back outlet (HWAM 4560)
- HWAM 4550m/4560m are available in black, grey and white
- HWAM 4550c/4560c are available in black and grey
- HWAM 4560 with stone cladding is available in black and grey

Accessories

- Combustion air system, rear/bottom
- Heat storage stones

Approvals and registrations

- EN 13240
- NS 3058/3059
- Art. 15a
- BlmSchV Stufe 2
- LRV
- RLU
- Brændeovnsbekendtgørelsen 2018



Combustion air system



HWAM 4550m with side glass



HWAM 4560c



HWAM 4560m with soapstone cladding

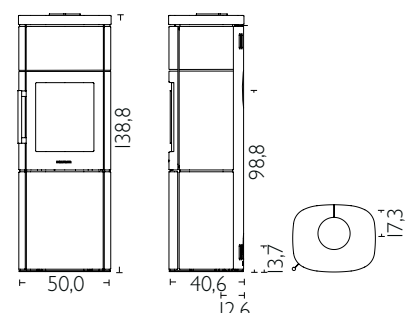
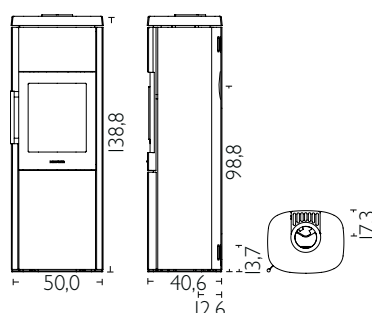
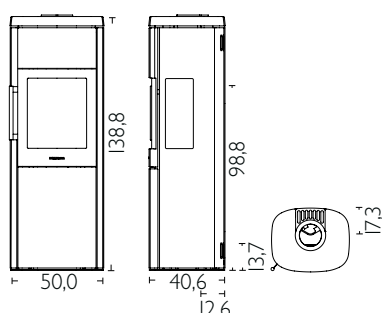
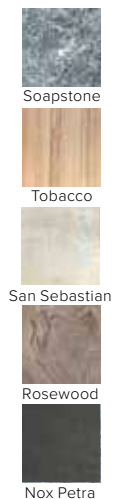

All drawings: The measurements for the flue outlet and fresh air connection are to the centre of the hole.

HWAM 4620/4640

Technical data

Capacity	3-9 kW
Nominal heat output Autopilot™/SmartControl™	7.0/8.0 kW
Smoke outlet	Ø 150 mm
Net efficiency Autopilot™/ SmartControl™	80/81%
Chimney draught, min. (recommended)	12 Pa
Energy efficiency class Autopilot™/SmartControl™	A/A+

Weight

Weight HWAM 4620c/4620m	119/117 kg
Weight HWAM 4640c/4640m	133/131 kg
Weight with soapstone cladding HWAM 4640c/4640m	197/195 kg
Weight with natural stone cladding HWAM 4640c/4640m	182/180 kg

Measurements

Width of combustion chamber	49.0 cm
Connection from floor, top, HWAM 4620	81.9 cm
Connection from floor, top, HWAM 4640	111.4 cm

* Not HWAM SmartControl™

** Not HWAM 4620

Variants

- Autopilot™ (HWAM 4620/4640) or SmartControl™ (HWAM 4640)
- Classic door (c) or modern door (m)
- Cast iron top, top outlet or back outlet
- Soapstone cladding, top outlet or back outlet (HWAM 4640)
- Natural stone cladding, top outlet or back outlet (HWAM 4640)
- HWAM 4620m/4640m are available in black, grey and white
- HWAM 4620c/4640c are available in black and grey
- HWAM 4640 with stone cladding is available in black and grey

Accessories

Combustion air system, rear/bottom

Approvals and registrations

- EN 13240
- NS 3058/3059
- Art. 15a
- BImSchV Stufe 2
- LRV
- RLU
- Brændeovnsbekendtgørelsen 2018



Combustion air system



HWAM 4620c



HWAM 4640m



HWAM 4640m
with soapstone cladding

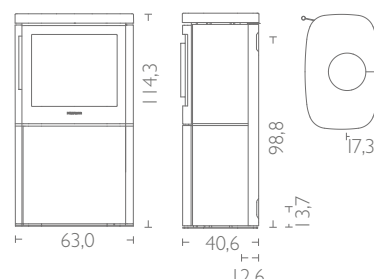
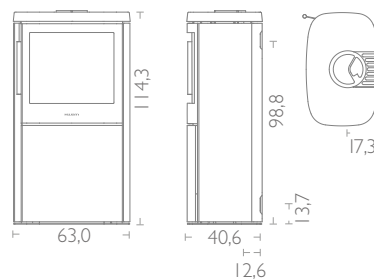
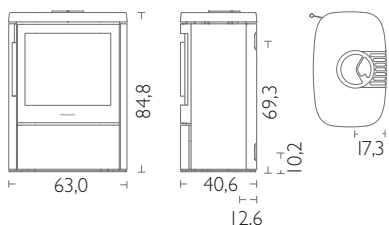
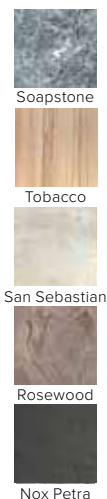

All drawings: The measurements for the flue outlet and fresh air connection are to the centre of the hole.



HWAM 4660

Technical data

Capacity	3-9 kW
Nominal heat output Autopilot™/SmartControl™	7.0/8.0 kW
Smoke outlet	Ø 150 mm
Net efficiency Autopilot™/ SmartControl™	80/81%
Chimney draught, min. (recommended)	12 Pa
Energy efficiency class Autopilot™/SmartControl™	A/A+

Weight

Weight HWAM 4660c/4660m	153/151 kg
Weight with soapstone cladding HWAM 4660c/4660m	224/222 kg
Weight with natural stone cladding HWAM 4660c/4660m	209/207 kg
Weight, heat storage stones	Ca. 45 kg

Measurements

Width of combustion chamber	49.0 cm
Connection from floor, top	111.4 cm

* Not HWAM® SmartControl™

Variants

Autopilot™ or SmartControl™
Classic door (c) or modern door (m)
Cast iron top, top outlet or back outlet
Soapstone cladding, top outlet or back outlet
Natural stone cladding, top outlet or back outlet
HWAM 4660m is available in black, grey and white
HWAM 4660c is available in black and grey
HWAM 4660 with stone cladding is available in black and grey

Accessories

Combustion air system, rear/bottom
Heat storing stone

Approvals and registrations

- EN 13240
- NS 3058/3059
- Art. 15a
- BImSchV Stufe 2
- LVR
- RLU
- Brændeovnsbekendtgørelsen 2018



Combustion air system



HWAM 4660c



HWAM 4660m
with Tobacco sandstone cladding

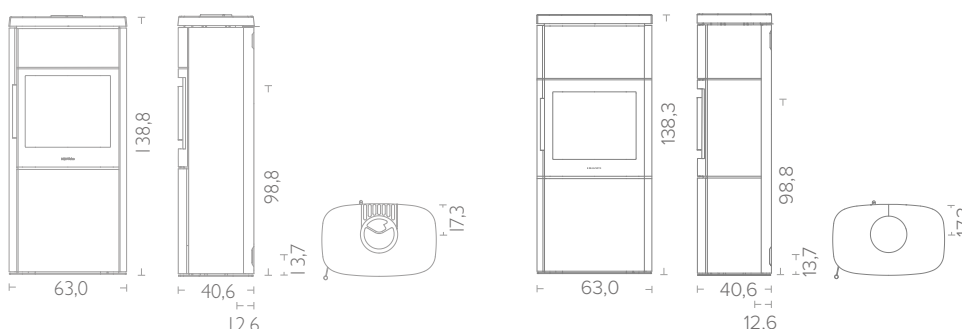

All drawings: The measurements for the flue outlet and fresh air connection are to the centre of the hole.

HWAM 5530

Technical data

Capacity	4-8 kW
Nominal heat output Autopilot™/SmartControl™	6.4/6.0 kW
Smoke outlet	Ø 150 mm
Net efficiency Autopilot™/ SmartControl™	80/83%
Chimney draught, min. (recommended) Autopilot™/ SmartControl™	11/12 Pa
Energy efficiency class Autopilot™/SmartControl™	A/A+

Weight

Weight HWAM 5530c/5530m	247/245 kg
Weight tall bookcase	56 kg
Weight narrow module without/with drawer	25/37 kg
Weight wide module without/with drawer	45/55 kg
Weight, heat storage stones	Ca. 137 kg

Measurements

Width of combustion chamber	44.3-62.7 cm
Connection from floor, top,	160.0 cm

Variants

- Autopilot™ or SmartControl™
- Classic door (c) or modern door (m)
- Optional right or left hinged door
- Steel top, top outlet, back outlet or side outlet
- HWAM 5530c/5530m are available in black

Accessories

- Tall bookcase
- Narrow module without/with drawer (front in oak/walnut) incl. felt cushion
- Wide module without/with drawer (front in oak/walnut) incl. felt cushion
- Heat storage stones
- Combustion air system, rear/bottom

Approvals and registrations

- EN 13240
- NS 3058/3059
- Art. 15a
- BlmSchV Stufe 2
- LRV
- RLU
- Brændeovnsbekendtgørelsen 2018



Combustion air system



HWAM 5530c with right hinged door



HWAM 5530m with right hinged door



Right hinged door



Left hinged door

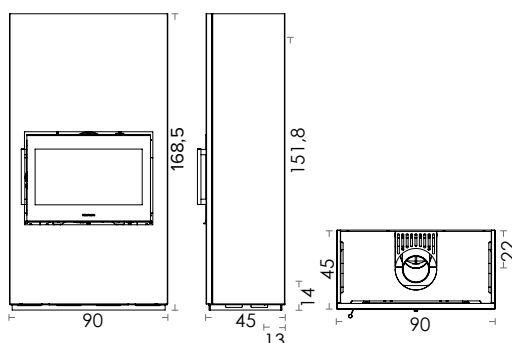

All drawings: The measurements for the flue outlet and fresh air connection are to the centre of the hole.



HWAM 5530

Setting Examples

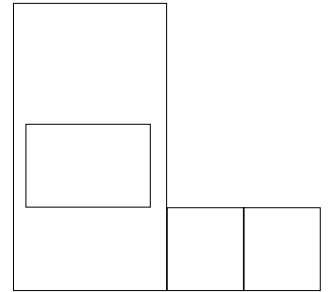
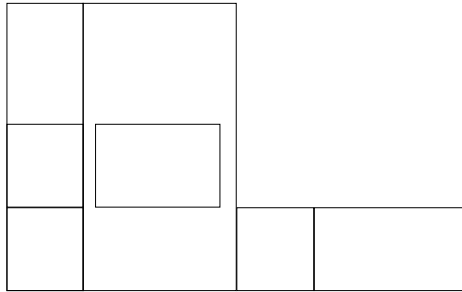
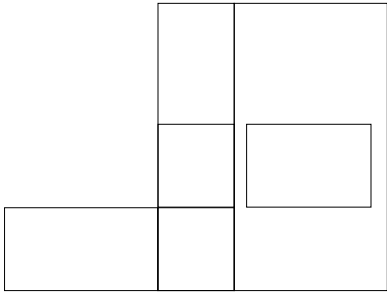

Tall bookcase



Narrow module without drawer



Narrow module with drawer, oak front



Narrow module with drawer, walnut front



Felt cushion for narrow module



Wide module without drawer



Wide module with drawer, oak front



Wide module with drawer, walnut front



Felt cushion for wide module

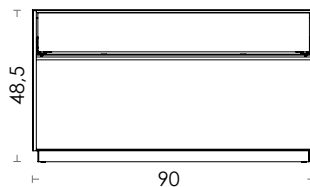
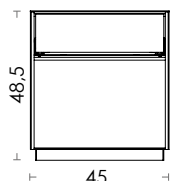
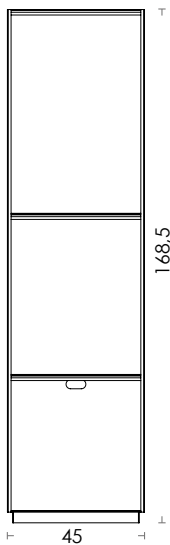

HWAM Classic 4

Technical data

Capacity	3-8 kW
Nominal heat output	8 kW
Smoke outlet	Ø 150 mm
Net efficiency	79.3%
Chimney draught, min. (recommended)	12 Pa
Energy efficiency class	A

Weight

Weight	108 kg
Weight with wood store	120 kg
Weight with a baking oven	178 kg
Weight with wood store and baking oven	190 kg

Measurements

Width of combustion chamber	40.0 cm
Baking oven, H x W x D	22.5 x 46.6 x 23.7 cm
Connection from floor, top*	68.7 cm
Connection from floor with wood store, top	90.7 cm
Connection from floor with baking oven, top	108.5 cm
Connection from floor with wood store and baking oven, top	130.5 cm

* Without wood store.

Variants

Autopilot™
Top outlet or back outlet (not with baking oven)
Wood store
Baking oven
HWAM Classic 4 is available in black and grey

Accessories

Combustion air system, rear

Approvals and registrations

- EN 13240
- BImSchV Stufe 2
- LRV



Combustion air system



HWAM Classic 4



HWAM Classic 4 with wood store and baking oven

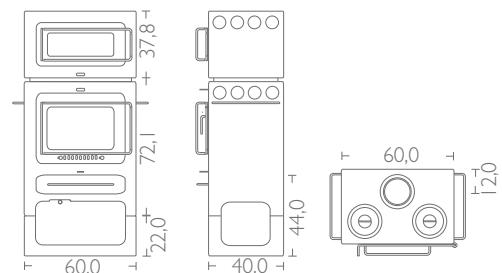
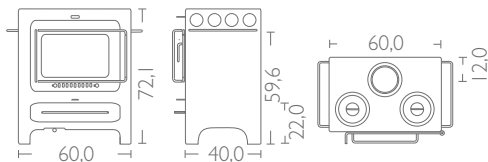

HWAM I 40/55

Technical data

Capacity	4-8 kW
Nominal heat output Autopilot™/SmartControl™	6.4/6.0 kW
Smoke outlet	Ø150 mm
Net efficiency Autopilot™/SmartControl™	80/83%
Chimney draught, min. (recommended) Autopilot™/SmartControl™	11/12 Pa
Energy efficiency class Autopilot™/SmartControl™	A/A+

Weight

Weight HWAM I 40/55c/I 40/55m	97/99 kg
-------------------------------	----------

Measurements

Width of combustion chamber	62.7 cm
-----------------------------	---------

Variants

- Autopilot™ or SmartControl™
- Classic (c) or modern (m) door
- Optional right or left hinged door
- Top outlet or back outlet
- HWAM I 40/55 is available in black

Accessories

- Combustion air system
- Fan kit
- Customised frame

Approvals and registrations

- EN 13229
- NS 3058/3059
- BlmSchV Stufe 2
- LRV
- RLU
- Brændeovnsbekendtgørelsen 2018



Combustion air system



HWAM I 40/55m right hinged door



HWAM I 40/55c left hinged door

HWAM® SmartControl™

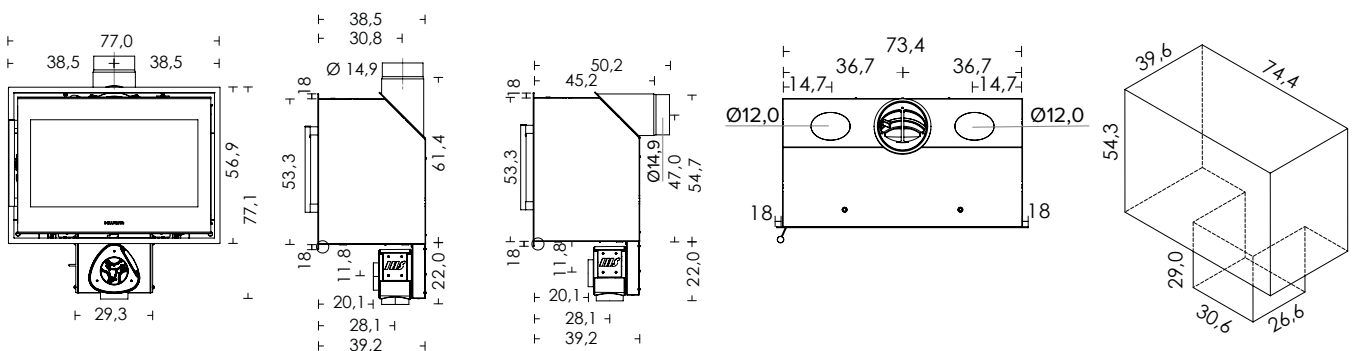

HWAM® Autopilot™

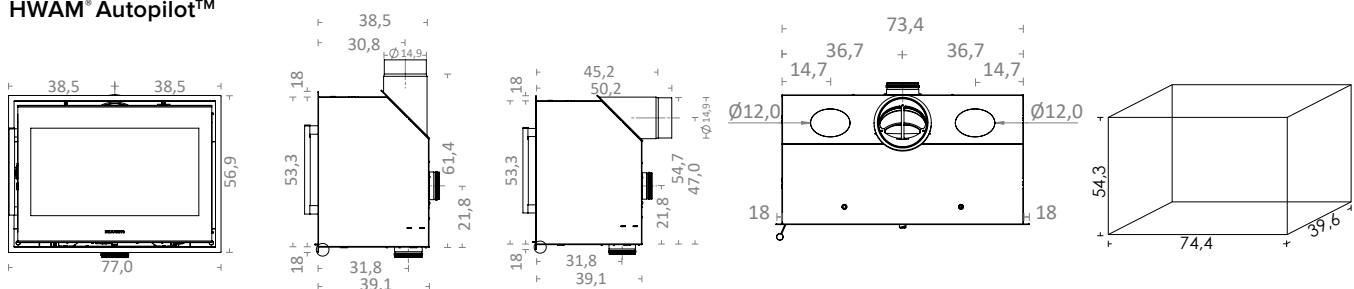

Product overview

	Function					Design												Connection			
	Nominal heat output <5 kW	Nominal heat output 5-6 kW	Nominal heat output >6 kW	HWAM® Autopilot™	HWAM® SmartControl™	Classic door	Modern door	Side hinged door	Optional handle	Optional right or left hinged door	Side glass	Wall-mounted	Pedestal or/and plinth	Heat storage compartment	White	Grey	Black	Soapstone cladding/Natural stone cladding	Wood store	Combustion air system bottom	Combustion air system rear
HWAM 2610c	x			x		x		x			x	x	x			x	x			x	x
HWAM 2610m	x			x			x	x			x	x	x		x	x	x			x	x
HWAM 2620c	x			x		x		x				x	x			x	x			x	x
HWAM 2620m	x			x			x	x				x	x		x	x	x			x	x
HWAM 2630c	x			x		x		x			x					x	x			x	x
HWAM 2630m	x			x			x	x			x				x	x	x			x	x
HWAM 2640c	x			x		x		x								x	x			x	x
HWAM 2640m	x			x			x	x							x	x	x			x	x
HWAM 3110c	x			x		x		x	x			x	x			x	x			x	x
HWAM 3110m	x			x			x	x	x			x	x		x	x	x			x	x
HWAM 3120c	x			x	x	x		x	x							x	x			x	x
HWAM 3120m	x			x	x		x	x	x						x	x	x			x	x
HWAM 3130c	x			x	x	x		x	x				x		x	x				x	x
HWAM 3130m	x			x	x		x	x	x				x		x	x	x			x	x
HWAM 3520c	x			x	x	x		x	x				x		x	x	x	x		x	x
HWAM 3520m	x			x	x		x	x	x				x		x	x	x	x		x	x
HWAM 3630c		x		x	x	x		x			x					x	x			x	x
HWAM 3630m		x		x	x		x	x			x				x	x	x			x	x
HWAM 3640c		x		x	x	x		x								x	x	x		x	x
HWAM 3640m		x		x	x		x	x							x	x	x	x		x	x
HWAM 3650c		x		x	x	x		x			x			x		x	x			x	x
HWAM 3650m		x		x	x		x	x			x			x	x	x	x			x	x
HWAM 3660c		x		x	x	x		x						x		x	x	x		x	x
HWAM 3660m		x		x	x		x	x						x	x	x	x	x		x	x
HWAM 3740c	x			x	x	x		x	x							x	x			x	x
HWAM 3740m	x			x	x		x	x	x							x	x			x	x
HWAM 3760c	x			x	x	x		x	x					x		x	x			x	x
HWAM 3760m	x			x	x		x	x	x					x		x	x			x	x
HWAM 4110	x			x	x			x			x					x	x			x	x
HWAM 4120	x			x	x			x								x	x			x	x
HWAM 4130	x			x	x			x			x					x	x			x	x
HWAM 4140	x			x	x			x								x	x			x	x
HWAM 4150	x			x	x			x			x			x		x	x			x	x
HWAM 4160	x			x	x			x						x		x	x			x	x



Product overview

	Function					Design											Connection				
	Nominal heat output <5 kW	Nominal heat output 5-6 kW	Nominal heat output >6 kW	HWAM® Autopilot™	HWAM® SmartControl™	Classic door	Modern door	Side hinged door	Optional handle	Optional right or left hinged door	Side glass	Wall-mounted	Pedestal or/and plinth	Heat storage compartment	White	Grey	Black	Soapstone cladding/Natural stone cladding	Wood store	Combustion air system bottom	Combustion air system rear
HWAM 4240	x			x	x			x								x	x	x		x	x
HWAM 4340		x		x	x			x								x	x	x		x	x
HWAM 4510c	x			x	x	x		x		x	x	x				x	x			x	x
HWAM 4510m	x			x	x		x	x		x	x	x		x	x	x				x	x
HWAM 4520c	x			x	x	x		x			x	x				x	x			x	x
HWAM 4520m	x			x	x		x	x			x	x		x	x	x				x	x
HWAM 4530c	x			x	x	x		x		x						x	x			x	x
HWAM 4530m	x			x	x		x	x		x				x	x	x				x	x
HWAM 4540c	x			x	x	x		x								x	x	x		x	x
HWAM 4540m	x			x	x		x	x						x	x	x	x			x	x
HWAM 4550c	x			x	x	x		x		x			x		x	x				x	x
HWAM 4550m	x			x	x		x	x		x			x	x	x	x				x	x
HWAM 4560c	x			x	x	x		x					x		x	x	x			x	x
HWAM 4560m	x			x	x		x	x					x	x	x	x	x			x	x
HWAM 4620c			x	x		x		x							x	x				x	x
HWAM 4620m			x	x			x	x						x	x	x				x	x
HWAM 4640c			x	x	x	x		x							x	x	x			x	x
HWAM 4640m			x	x	x		x	x						x	x	x	x			x	x
HWAM 4660c			x	x	x	x		x					x		x	x	x			x	x
HWAM 4660m			x	x	x		x	x					x	x	x	x	x			x	x
HWAM 5530c		x	x	x	x	x		x		x			x			x				x	x
HWAM 5530m		x	x	x	x		x	x		x			x			x				x	x
HWAM Classic 4				x	x			x									x	x			x
HWAM I 40/55c		x	x	x	x	x		x		x							x			x	x ¹⁾
HWAM I 40/55m		x	x	x	x		x	x		x							x			x	x ¹⁾

1) HWAM® SmartControl™: See drawing.

Distance to combustible materials

- insulated flue gas pipe/uninsulated flue gas pipe

	1. Behind Cm. min	2. Side Cm. min.	3. Distance to furnishing in front Cm. min.	4. Above combustible floor Cm. min.	May be installed on a 12 mm thick hearth on combustible floor (UK)	5. Distance to combustible wall, corner location Cm. min	6. Distance to combustible wall, corner location Cm. min.
HWAM 2610	19	36	80	3 ⁽⁴⁾	x ⁽⁸⁾	34 ⁽³⁾	56 ⁽³⁾
HWAM 2620	19	36	80	3 ⁽⁴⁾	x ⁽⁸⁾	20 ⁽³⁾	42 ⁽³⁾
HWAM 2630	19	36	80	-	x	34 ⁽³⁾	56 ⁽³⁾
HWAM 2640	19	36	80	-	x	20 ⁽³⁾	42 ⁽³⁾
HWAM 3110	10	20	80	3 ⁽⁴⁾	x ⁽⁸⁾	13	34
HWAM 3120	10	20	80	-	x	13	34
HWAM 3130	10	20	80	-	x	13	34
HWAM 3520	10	20	80	-	x	13	43
HWAM 3630	10	40	90	-	x	35 ⁽³⁾	63 ⁽³⁾
HWAM 3640	10	40	90	-	x	20 ⁽³⁾	48 ⁽³⁾
HWAM 3650	10	40	90	-	x	35 ⁽³⁾	63 ⁽³⁾
HWAM 3660	10	40	90	-	x	20 ⁽³⁾	48 ⁽³⁾
HWAM 3740	10	35	90	-	x	9	33
HWAM 3760	10	35	90	-	x	9	33
HWAM 4110	10	42	90	-	x	10	35,5
HWAM 4120	10/15	42	110	-	x	10	35,5
HWAM 4130	10	42	90	-	x	10	35,5
HWAM 4140	10/15	42	110	-	x	10	35,5
HWAM 4150	10	42	90	-	x	10	35,5
HWAM 4160	10/15	42	110	-	x	10	35,5

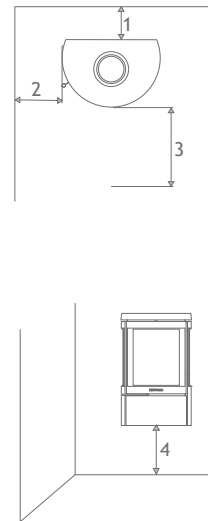

HWAM 2610
HWAM 2620
HWAM 2630
HWAM 2640

HWAM 3110
HWAM 3120
HWAM 3130

HWAM 3520

HWAM 3630
HWAM 3640
HWAM 3650
HWAM 3660

HWAM 3740
HWAM 3760

HWAM 4110
HWAM 4120
HWAM 4130
HWAM 4140
HWAM 4150
HWAM 4160

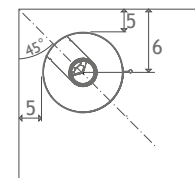
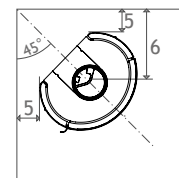
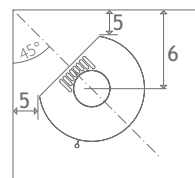
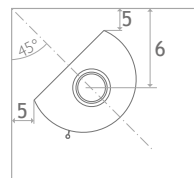
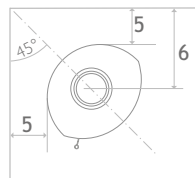
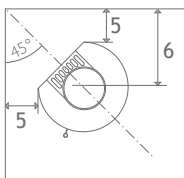

(1) Thickness of insulation, behind/under/over.

(2) Thickness of insulation.

(3) **Important!** All dimensions in connection with corner installation are only recommendations. Contact your HETAS Engineer for a clarification.

(4) This distance requirement is met when the stove is mounted on a plinth or a Pedestal.

(5) With insulated flue pipe

(6) This distance requirement is met when the stove is mounted on a high plinth.

(7) Distance to non combustible insulation against combustible wall.

(8) Can be installed on a 12 mm hearth, when mounted on a 3 cm plinth.

(9) Can be installed on a 12 mm hearth when mounted on a low plinth.

Distance to combustible materials

- insulated flue gas pipe/uninsulated flue gas pipe

	1. Behind Cm. min.	2. Side Cm. min.	3. Distance to furnishing in front Cm. min.	4. Above combustible floor Cm. min.	May be installed on a 12 mm thick hearth on combustible floor (UK)	5. Distance to combustible wall, corner location Cm. min.	6. Distance to combustible wall, corner location Cm. min.
HWAM 4240	10/15	42	110	-	x	10	36,8
HWAM 4340	11	25	120	-	x	13	34,5
HWAM 4510	10	59	120	28,5 ⁽⁶⁾	x ⁽⁹⁾	33	57
HWAM 4520	10	35	110	28,5 ⁽⁶⁾	x ⁽⁹⁾	7	31
HWAM 4530	10	59	120	-	x	33	57
HWAM 4540	10	35	110	-	x	7	31
HWAM 4540, stone cladding	10	40	110	-	x	7	31
HWAM 4550	10	59	120	-	x	33	57
HWAM 4560	10	35	110	-	x	7	31
HWAM 4560, stone cladding	10	40	110	-	x	7	31
HWAM 4620	7/20	40/35	130	-	x	12/12	41/41
HWAM 4640	7/20	40/35	130	-	x	12/12	41/41
HWAM 4640, stone cladding	7/20	45/45	140	-	x	15/15	44/44
HWAM 4660	7/20	40/35	130	-	x	12/12	41/41
HWAM 4660, stone cladding	7/20	45/45	140	-	x	15/15	44/44
HWAM 5530	0/5	0	120	-	x	0	47,7
HWAM Classic 4	10	25	80	-	x	10 ⁽³⁾	39 ⁽³⁾
HWAM I 40/55	5 ⁽⁷⁾	5 ⁽⁷⁾	120	35		-	-

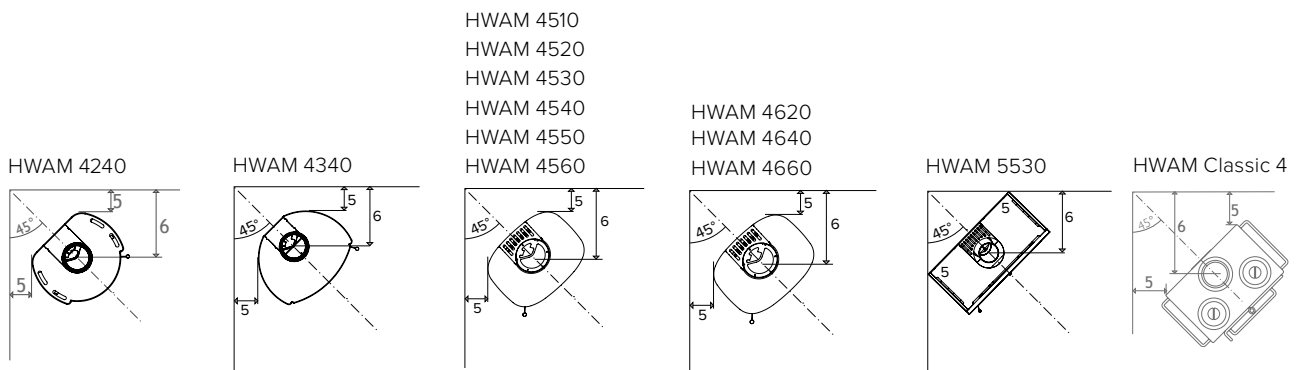
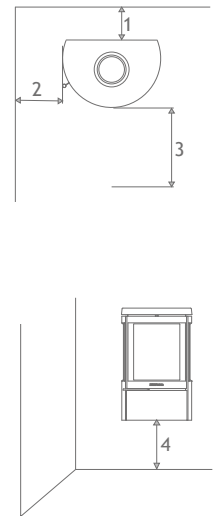

Test results

	EN 13240/13229					Art. 15a		NS 3058 NS 3059
	CO at 13% O ₂	CO at 13% O ₂	Particle emission at 13% O ₂	Flue gas temperature measured in the outlet socket	Flue gas mass flow	Particle emission	CO	Particle emission
	%	mg/m ³ _n	mg/m ³ _n	°C	g/s	mg/MJ	mg/MJ	
HWAM 2610, Autopilot™	0.10	1250	22	366	3.72	-	-	3.42
HWAM 2620, Autopilot™	0.10	1250	22	366	3.72	-	-	3.42
HWAM 2630, Autopilot™	0.10	1250	22	366	3.72	-	-	3.42
HWAM 2640, Autopilot™	0.10	1250	22	366	3.72	-	-	3.42
HWAM 3110, Autopilot™	0.07	875	22	300	5.10	-	-	2.05
HWAM 3120, Autopilot™	0.07	875	22	300	5.10	-	-	2.05
HWAM 3120, SmartControl™	0.08	1000	20	307	3.66	13	630	2.45
HWAM 3130, Autopilot™	0.07	875	22	300	5.10	-	-	2.05
HWAM 3130, SmartControl™	0.08	1000	20	307	3.66	13	630	2.45
HWAM 3520, Autopilot™	0.07	875	22	300	5.10	-	-	2.05
HWAM 3520, SmartControl™	0.08	1000	20	307	3.66	13	630	2.45
HWAM 3630, Autopilot™	0.09	1125	18	350	6.00	-	-	1.21
HWAM 3630, SmartControl™	0.10	1250	21	325	5.04	13	756	1.78
HWAM 3640, Autopilot™	0.09	1125	18	350	6.00	-	-	1.21
HWAM 3640, SmartControl™	0.10	1250	21	325	5.04	13	756	1.78
HWAM 3650, Autopilot™	0.09	1125	18	350	6.00	-	-	1.21
HWAM 3650, SmartControl™	0.10	1250	21	325	5.04	13	756	1.78
HWAM 3660, Autopilot™	0.09	1125	18	350	6.00	-	-	1.21
HWAM 3660, SmartControl™	0.10	1250	21	325	5.04	13	756	1.78
HWAM 3740, Autopilot™	0.07	875	22	300	5.10	-	-	2.05
HWAM 3740, SmartControl™	0.08	1000	20	307	3.66	13	630	2.45
HWAM 3760, Autopilot™	0.07	875	22	300	5.10	-	-	2.05
HWAM 3760, SmartControl™	0.08	1000	20	307	3.66	13	630	2.45
HWAM 4110, Autopilot™	0.09	1125	24	232	5.30	18	825	4.81
HWAM 4110, SmartControl™	0.08	1000	12	257	3.70	9	714	4.46
HWAM 4120, Autopilot™	0.09	1125	24	232	5.30	18	825	4.81
HWAM 4120, SmartControl™	0.08	1000	12	257	3.70	9	714	4.46
HWAM 4130, Autopilot™	0.09	1125	24	232	5.30	18	825	4.81
HWAM 4130, SmartControl™	0.08	1000	12	257	3.70	9	714	4.46
HWAM 4140, Autopilot™	0.09	1125	24	232	5.30	18	825	4.81
HWAM 4140, SmartControl™	0.08	1000	12	257	3.70	9	714	4.46
HWAM 4150, Autopilot™	0.09	1125	24	232	5.30	18	825	4.81
HWAM 4150, SmartControl™	0.08	1000	12	257	3.70	9	714	4.46
HWAM 4160, Autopilot™	0.09	1125	24	232	5.30	18	825	4.81
HWAM 4160, SmartControl™	0.08	1000	12	257	3.70	9	714	4.46

NB! Due to the constant improvements of our products the valid values may vary from the above mentioned. Updated values are available at your local HWAM retailer and can be seen on www.hwam.com.

Test results



	EN 13240/13229					Art. 15a		NS 3058 NS 3059
	CO at 13% O ₂	CO at 13% O ₂	Particle emission at 13% O ₂	Flue gas temperature measured in the outlet socket	Flue gas mass flow	Particle emission	CO	Particle emission
	%	mg/m ³ _n	mg/m ³ _n	°C	g/s	mg/MJ	mg/MJ	g/kg
HWAM 4240, Autopilot™	0.09	1125	24	232	5.30	18	825	4.81
HWAM 4240, SmartControl™	0.08	1000	12	257	3.70	9	714	4.46
HWAM 4340, Autopilot™	0.09	1125	25	355	5.10	17	717	3.73
HWAM 4340, SmartControl™	0.10	1250	28	321	4.70	18	797	1.16
HWAM 4510, Autopilot™	0.08	1000	24	312	4.1	18	752	3.01
HWAM 4510, SmartControl™	0.06	750	19	324	4.0	15	586	2.16
HWAM 4520, Autopilot™	0.08	1000	24	312	4.1	18	752	3.01
HWAM 4520, SmartControl™	0.06	750	19	324	4.0	15	586	2.16
HWAM 4530, Autopilot™	0.08	1000	24	312	4.1	18	752	3.01
HWAM 4530, SmartControl™	0.06	750	19	324	4.0	15	586	2.16
HWAM 4540, Autopilot™	0.08	1000	24	312	4.1	18	752	3.01
HWAM 4540, SmartControl™	0.06	750	19	324	4.0	15	586	2.16
HWAM 4550, Autopilot™	0.08	1000	24	312	4.1	18	752	3.01
HWAM 4550, SmartControl™	0.06	750	19	324	4.0	15	586	2.16
HWAM 4560, Autopilot™	0.08	1000	24	312	4.1	18	752	3.01
HWAM 4560, SmartControl™	0.06	750	19	324	4.0	15	586	2.16
HWAM 4620, Autopilot™	0.08	1000	28	320	5.9	19	659	1.74
HWAM 4640, Autopilot™	0.08	1000	28	320	5.9	19	659	1.74
HWAM 4640, SmartControl™	0.06	750	29	334	6.6	19	515	1.88
HWAM 4660, Autopilot™	0.08	1000	28	320	5.9	19	659	1.74
HWAM 4660, SmartControl™	0.06	750	29	334	6.6	19	515	1.88
HWAM 5530, Autopilot™	0.061	758	16	326	5.5	11	383	2.65
HWAM 5530, SmartControl™	0.077	963	16	299	4.6	10	552	1.87
HWAM Classic 4	0.10	1250	36	255	9.90	-	-	-
HWAM I 40/55 Autopilot™	0.061	758	16	326	5.5	11	383	2.65
HWAM I 40/55 SmartControl™	0.077	963	16	299	4.6	10	553	1.87

NB! Due to the constant improvements of our products the valid values may vary from the above mentioned. Updated values are available at your local HWAM retailer and can be seen on www.hwam.com.

Approvals & registrations

	EN 13229 (Europa)	EN 13240 (Europa)	Art. 15a (Austria)	NS 3058/3059 (Norway)	Brændeovnsbekendtgørelsen 2018 (Denmark)	LRV (Switzerland)	BImSchV Stufe 2 (Germany)	RLU zugelassen (Germany)	DEFRA exempt (UK)	HETAS (UK)	Flamme Verte (France)
HWAM 2610		x		x	x	x	x		x	x	x
HWAM 2620		x		x	x	x	x		x	x	x
HWAM 2630		x		x	x	x	x	x	x	x	x
HWAM 2640		x		x	x	x	x	x	x	x	x
HWAM 3110		x		x	x	x	x		x ⁽³⁾	x	x
HWAM 3120		x	x ⁽¹⁾	x	x	x	x	x	x ⁽³⁾	x	x
HWAM 3130		x	x ⁽¹⁾	x	x	x	x	x		x	x
HWAM 3520		x	x ⁽¹⁾	x	x	x	x	x	x ⁽³⁾	x	x
HWAM 3630		x	x ⁽¹⁾	x	x	x	x	x	x ⁽³⁾	x ⁽³⁾	x
HWAM 3640		x	x ⁽¹⁾	x	x	x	x	x	x ⁽³⁾	x ⁽³⁾	x
HWAM 3650		x	x ⁽¹⁾	x	x	x	x	x	x ⁽³⁾	x ⁽³⁾	x
HWAM 3660		x	x ⁽¹⁾	x	x	x	x	x	x ⁽³⁾	x ⁽³⁾	
HWAM 3740		x	x ⁽¹⁾	x	x	x	x			x	x
HWAM 3760		x	x ⁽¹⁾	x	x	x	x			x	x
HWAM 4110		x	x	x	x	x	x		x	x	
HWAM 4120		x	x	x	x	x	x		x	x	
HWAM 4130		x	x	x	x	x	x		x	x	
HWAM 4140		x	x	x	x	x	x		x	x	
HWAM 4150		x	x	x	x	x	x		x	x	
HWAM 4160		x	x	x	x	x	x		x	x	
HWAM 4240		x	x	x	x	x	x		x	x	
HWAM 4340		x	x	x	x	x	x		x	x	
HWAM 4510		x	x	x	x	x	x	x	x	x	
HWAM 4520		x	x	x	x	x	x	x	x	x	
HWAM 4530		x	x	x	x	x	x	x	x	x	
HWAM 4540		x	x	x	x	x	x	x	x	x	x
HWAM 4550		x	x	x	x	x	x	x	x	x	
HWAM 4560		x	x	x	x	x	x	x	x	x	x
HWAM 4620		x	x	x	x	x	x	x	x	x ⁽³⁾	x
HWAM 4640		x	x	x	x	x	x	x	x	x ⁽³⁾	x
HWAM 4660		x	x	x	x	x	x	x	x	x ⁽³⁾	x
HWAM 5530		x	x	x	x	x	x	x	x	x	x
HWAM Classic 4		x				x	x				x
HWAM I 40/55	x		x	x	x	x	x	x	x	x	x

(1) Applies only to models with HWAM® SmartControl™.

(2) Pending registration

(3) Applies only to models with HWAM® Autopilot™.

NB! The table shows the status at the time of the catalogue's publication.

The current status can be obtained at any time from your HWAM dealer and can be checked on www.hwam.com.



